



CAR AGA 2

HELIPORTS

FOREWORD

CONTENTS

REVISION RECORD

LIST of EFFECTIVE PAGES



This Page Intentionally Left Blank



FOREWORD

1. The Civil Aviation Authority Bahamas is known in these regulations as the “Authority” and has implemented CAR AGA 2 - Civil Aviation Regulations – Aerodromes and Ground Aids - Heliports. The regulations are made under the Civil Aviation Authority Act – 2021.

Notes:

- (a) *All aerodromes and heliports, regardless of use, must be registered.*
 - (b) *Heliports, capable of being certified, are addressed in CAR AGA 2.*
 - (c) *Heliports, either temporarily or permanently incapable of certification, may be licensed under CAR AGA 2, Chapter 10.*
2. Any reference in this regulation to an Annex to the Chicago Convention includes any differences, present or future, notified to ICAO by the Authority in respect of the Standards specified in that Annex. The structure and substance of these regulations is based on Annex 14, Volume II to the Convention on International Civil Aviation. Appendices to ICAO Annex 14 Volume II are not included in these regulations and require compliance when referred to.
 3. Unless otherwise stated, applicable CAR DEF definitions and abbreviations are used throughout this document.
 4. The editing practices used in this document are as follows:
 - (a) ‘Shall’ or ‘Will’ or ‘Must’ is used to indicate a mandatory requirement.
 - (b) ‘Should’ is used to indicate a recommendation.
 - (c) ‘May’ is used to indicate discretion by the Authority, the industry or the applicant, as appropriate.

Note: The use of the male gender implies all genders.

5. Paragraphs and sub-paragraphs with new, amended and corrected text will be enclosed within brackets until a subsequent “amendment” is issued.
6. Manuals related to the specifications of CAR AGA 2;
 - (a) Aerodrome Design Manual (Doc 9157)
 - Part 1 — Runways
 - Part 2 — Taxiways, Aprons and Holding Bays
 - Part 3 — Pavements
 - Part 4 — Visual Aids
 - Part 5 — Electrical Systems
 - Part 6 — Frangibility
 - (b) Airport Planning Manual (Doc 9184)
 - Part 1 — Master Planning
 - Part 2 — Land Use and Environmental Control
 - Part 3 — Guidelines for Consultant/Construction Services



- (c) Airport Services Manual (Doc 9137)
 - Part 1 — Rescue and Firefighting
 - Part 2 — Pavement Surface Conditions
 - Part 3 — Wildlife Control and Reduction
 - Part 4 — Fog Dispersal (withdrawn)
 - Part 5 — Removal of Disabled Aircraft
 - Part 6 — Control of Obstacles
 - Part 7 — Airport Emergency Planning
 - Part 8 — Airport Operational Services
 - Part 9 — Airport Maintenance Practices
- (d) Heliport Manual (Doc 9261)
- (e) Manual of Surface Movement Guidance and Control Systems (SMGCS) (Doc 9476)
- (f) Manual on the ICAO Bird Strike Information System (IBIS) (Doc 9332)
- (g) World Geodetic System — 1984 (WGS-84) Manual (Doc 9674).



REVISION RECORD

REVISION NO.	EFFECTIVE DATE	ENTERED BY <i>(Hardcopy only)</i>
Initial Issue	25 March 2021	



LIST OF EFFECTIVES PAGES

i 25 Mar 21
 ii 25 Mar 21
 iii 25 Mar 21
 iv 25 Mar 21
 v 25 Mar 21
 vi 25 Mar 21
 vii 25 Mar 21
 viii 25 Mar 21
 ix 25 Mar 21
 x 25 Mar 21

SECTION 1

Chapter 1

1-1 25 Mar 21
 1-2 25 Mar 21
 1-3 25 Mar 21
 1-4 25 Mar 21
 1-5 25 Mar 21
 1-6 25 Mar 21
 1-7 25 Mar 21
 1-8 25 Mar 21

Chapter 2

2-1 25 Mar 21
 2-2 25 Mar 21
 2-3 25 Mar 21
 2-4 25 Mar 21

Chapter 3

3-1 25 Mar 21
 3-2 25 Mar 21
 3-3 25 Mar 21
 3-4 25 Mar 21
 3-5 25 Mar 21
 3-6 25 Mar 21
 3-7 25 Mar 21
 3-8 25 Mar 21
 3-9 25 Mar 21
 3-10 25 Mar 21
 3-11 25 Mar 21
 3-12 25 Mar 21
 3-13 25 Mar 21
 3-14 25 Mar 21
 3-15 25 Mar 21
 3-16 25 Mar 21
 3-17 25 Mar 21
 3-18 25 Mar 21

Chapter 4

4-1 25 Mar 21
 4-2 25 Mar 21
 4-3 25 Mar 21
 4-4 25 Mar 21
 4-5 25 Mar 21
 4-6 25 Mar 21
 4-7 25 Mar 21
 4-8 25 Mar 21
 4-9 25 Mar 21
 4-10 25 Mar 21
 4-11 25 Mar 21
 4-12 25 Mar 21
 4-13 25 Mar 21
 4-14 25 Mar 21
 4-15 25 Mar 21
 4-16 25 Mar 21

Chapter 5

5-1 25 Mar 21
 5-2 25 Mar 21
 5-3 25 Mar 21
 5-4 25 Mar 21
 5-5 25 Mar 21
 5-6 25 Mar 21
 5-7 25 Mar 21
 5-8 25 Mar 21
 5-9 25 Mar 21
 5-10 25 Mar 21
 5-11 25 Mar 21
 5-12 25 Mar 21
 5-13 25 Mar 21
 5-14 25 Mar 21
 5-15 25 Mar 21
 5-16 25 Mar 21
 5-17 25 Mar 21
 5-18 25 Mar 21
 5-19 25 Mar 21
 5-20 25 Mar 21
 5-21 25 Mar 21
 5-22 25 Mar 21
 5-23 25 Mar 21
 5-24 25 Mar 21
 5-25 25 Mar 21
 5-26 25 Mar 21
 5-27 25 Mar 21
 5-28 25 Mar 21
 5-29 25 Mar 21
 5-30 25 Mar 21

Chapter 6

6-1 25 Mar 21
 6-2 25 Mar 21
 6-3 25 Mar 21
 6-4 25 Mar 21

Chapter 7

7-1 25 Mar 21
 7-2 25 Mar 21
 7-3 25 Mar 21
 7-4 25 Mar 21

Chapter 8

8-1 25 Mar 21
 8-2 25 Mar 21
 8-3 25 Mar 21
 8-4 25 Mar 21

Chapter 9

9-1 25 Mar 21
 9-2 25 Mar 21

Chapter 10

10-1 25 Mar 21
 10-2 25 Mar 21
 10-3 25 Mar 21
 10-4 25 Mar 21

Appendix 1

APP1-1 25 Mar 21
 APP1-2 25 Mar 21
 APP1-3 25 Mar 21
 APP1-4 25 Mar 21
 APP1-5 25 Mar 21
 APP1-6 25 Mar 21
 APP1-7 25 Mar 21
 APP1-8 25 Mar 21
 APP1-9 25 Mar 21
 APP1-10 25 Mar 21
 APP1-11 25 Mar 21
 APP1-12 25 Mar 21

SECTION 2

i 25 Mar 21



ii 25 Mar 21

Chapter 1

2-1-1 25 Mar 21
2-1-2 25 Mar 21
2-1-3 25 Mar 21
2-1-4 25 Mar 21

Chapter 7

2-7-1 25 Mar 21
2-7-2 25 Mar 21

Chapter 8

2-8-1 25 Mar 21
2-8-2 25 Mar 21

Chapter 9

2-9-1 25 Mar 21
2-9-2 25 Mar 21
2-9-3 25 Mar 21
2-9-4 25 Mar 21
2-9-5 25 Mar 21
2-9-6 25 Mar 21
2-9-7 25 Mar 21
2-9-8 25 Mar 21
2-9-9 25 Mar 21
2-9-10 25 Mar 21

Chapter 10

2-10-1 25 Mar 21
2-10-2 25 Mar 21

-End-



CONTENTS

Foreword	i
Revision Record	iii
List of Effective Pages	iv
Contents	vi
Advisory Circulars (AC) contents	ix
CHAPTER 1 GENERAL	1-1
1.1 Applicability	1-1
1.2 General	1-1
1.3 Requirements for registration of a heliport	1-2
1.4 Heliport operator responsibilities	1-2
1.5 Definitions, abbreviations and symbols	1-3
1.6 Operational coordination with service providers	1-5
1.7 Access to the heliport.....	1-6
1.8 Aeronautical studies	1-6
1.9 Operational directives.....	1-6
1.10 Common reference systems	1-7
1.11 Certification of heliports	1-7
1.12 Heliport design	1-7
1.13 Licensing of heliports	1-8
CHAPTER 2 HELIPORT DATA.....	2-1
2.1 Aeronautical data	2-1
2.2 Heliport reference point	2-1
2.3 Heliport elevations.....	2-1
2.4 Heliport dimensions and related information	2-1
2.5 Declared distances.....	2-2
2.6 Coordination between aeronautical information services and heliport authorities	2-2
2.7 Rescue and firefighting.....	2-3
CHAPTER 3 PHYSICAL CHARACTERISTICS	3-1
3.1 Surface-level heliports	3-1
Final Approach and Take-Off Areas	3-1
Helicopter clearways.....	3-2
Touchdown and Lift-Off Areas	3-3
Safety areas	3-3
Helicopter ground taxiways and helicopter ground taxi-routes	3-4
Helicopter air taxiways and air taxi-routes	3-5
Helicopter stands.....	3-6
Location of a Final Approach and Take-Off area in relation to a runway or taxiway ...	3-9
3.2 Elevated heliports.....	3-9
Final Approach And Take-Off areas and Touchdown and Lift-Off Areas	3-9
Helicopter clearways	3-10
Touchdown and Lift-Off Areas	3-10
Safety areas	3-11
Helicopter ground taxiways and ground taxi-routes	3-12
Helicopter air taxiways and air taxi-routes	3-12
Aprons	3-13



3.3	Helidecks.....	3-13
	Final Approach and Take-Off areas and Touchdown and Lift-Off Areas .	3-13
3.4	Shipboard heliports	3-15
	Final Approach and Take-Off areas and Touchdown and Lift-Off Areas .	3-15
CHAPTER 4	OBSTACLE ENVIRONMENT	4-1
4.1	Obstacle limitation surfaces and sectors	4-1
	Approach surface	4-1
	Transitional surface.....	4-6
	Take-off climb surface .	4-6
	Obstacle-free sector/surface — helidecks	4-7
	Limited obstacle sector/surface — helidecks	4-8
4.2	Obstacle limitation requirements	4-8
	Surface-level heliports	4-8
	Elevated heliports.....	4-11
	Helidecks	4-12
	Shipboard heliports	4-12
	Winching areas	4-14
CHAPTER 5	VISUAL AIDS	5-1
5.1	Indicators.....	5-1
5.1.1	Wind direction indicators	5-1
5.2	Markings and markers.....	5-2
5.2.1	Winching area marking.....	5-2
5.2.2	Heliport identification marking.....	5-3
5.2.3	Maximum allowable mass marking	5-3
5.2.4	D-value marking	5-5
5.2.5	Final Approach and Take-Off area dimension(s) marking.....	5-6
5.2.6	Final Approach and Take-Off area perimeter marking or markers for surface-level heliports	5-7
5.2.7	Final Approach and Take-Off area designation markings for runway-type FATOs	5-8
5.2.8	Aiming point marking.....	5-9
5.2.9	Touchdown and lift-off area perimeter marking	5-9
5.2.10	Touchdown/positioning marking	5-10
5.2.11	Heliport name marking	5-10
5.2.12	Helideck obstacle-free sector (chevron) marking	5-11
5.2.13	Helideck and shipboard heliport surface marking	5-12
5.2.14	Helideck prohibited landing sector markings	5-12
5.2.15	Helicopter ground taxiway markings and markers	5-12
5.2.16	Helicopter air taxiway markings and markers	5-13
5.2.17	Helicopter stand markings	5-14
5.2.18	Flight path alignment guidance marking	5-16
5.3	Lights	5-17
5.3.1	General	5-17
5.3.2	Heliport beacon.....	5-17
5.3.3	Approach lighting system	5-20
5.3.4	Flight path alignment guidance lighting system	5-20
5.3.5	Visual alignment guidance system.....	5-21
5.3.6	Visual Approach Slope Indicator.....	5-23
5.3.7	Final Approach and Take-Off area lighting systems for surface-level heliports	5-26
5.3.8	Aiming point lights	5-27



5.3.9	Touchdown and Lift-Off Area lighting system	5-27
5.3.10	Winching area floodlighting	5-29
5.3.11	Taxiway lights	5-30
5.3.12	Visual aids for denoting obstacles	5-30
5.3.13	Floodlighting of obstacles.....	5-30
CHAPTER 6	HELIPORT EMERGENCY RESPONSE	6-1
6.1	Heliport emergency planning	6-1
6.2	Rescue and firefighting	6-2
CHAPTER 7	CERTIFICATION PROCESS.....	7-1
7.1	General requirements for approval.....	7-1
7.2	Grant of a heliport certificate	7-2
7.3	Duration of a heliport certificate	7-2
7.4	Transfer of a heliport certificate	7-2
7.5	Amendment of a heliport certificate	7-3
7.6	Surrender of a heliport certificate	7-3
CHAPTER 8	HELIPORT OPERATIONS MANUAL	8-1
8.1	Requirement of the heliport operations manual	8-1
8.2	Preparation of the heliport operations manual (HOM)	8-1
8.3	Contents of the heliport operations manual	8-2
8.4	Amendment and location of the heliport operations manual	8-2
8.5	Heliport operations manual review	8-2
8.6	Approval of the heliport operations manual	8-3
CHAPTER 9	OBLIGATIONS OF THE HELIPORT OPERATOR	9-1
9.1	General	9-1
9.2	Records	9-1
9.3	Personnel competence and requirements	9-1
CHAPTER 10	LICENSING PROCESS	10-1
10.1	General requirements for approval.....	10-1
10.2	Grant of a heliport licence	10-2
10.3	Duration of a heliport licence	10-2
10.4	Transfer of a heliport licence	10-2
10.5	Amendment of a heliport licence	10-3
10.6	Surrender of a heliport licence	10-3
Appendix 1	Contents of the heliport operations manual (HOM).....	App 1-1



SECTION 2 - ADVISORY CIRCULARS (AC)

General i
 Presentation i

CHAPTER 1 GENERAL

AC 1.6.4 Service Level Agreements2-1-1
 AC 1.8 Aeronautical Studies2-1-2
 AC 1.11 Requirement for a heliport certificate2-1-1
 AC 1.13 Requirement for a heliport licence.....2-1-1

CHAPTER 7 CERTIFICATION PROCESS

AC 7.1 Certification process2-2-1
 AC 7.1.7 Key personnel.....2-2-1
 AC 7.2 Safety management systems.....2-2-2

CHAPTER 8 HELIPORT OPERATIONS MANUAL (HOM)

AC to Appendix 1 Preparation of the Heliport Operations Manual (HOM)2-3-1
 AC 8.3 Heliport Operations Manual (HOM) Compliance Letter2-3-2

CHAPTER 9 OBLIGATIONS OF THE HELIPORT OPERATOR

AC 9.1 General.....2-4-1
 AC 9.3.2 Personnel competence2-4-1
 AC 9.9 Rescue and firefighting2-4-4
 AC 9.9.1 Rescue and firefighting: categorising2-4-4
 AC 9.9.2 Rescue and firefighting: Equipment and extinguishing agents2-4-4
 AC 9.9.4 Rescue and firefighting: Response time.....2-4-5
 AC 9.9.9 Rescue and firefighting: operational requirements2-4-6
 AC 9.12 Heliport emergency planning2-4-6
 AC 9.13 Handling and storage of hazardous materials2-4-6
 AC 9.14 Guidance on a heliport safety management system.....2-4-7
 AC 9.15 Safety Audits and Inspections.....2-4-7
 AC 9.16 Vehicles2-4-7
 AC 9.17 Control of obstacles2-4-9
 AC 9.19 Public protection2-4-9
 AC 9.20 Protection against wildlife strike hazards.....2-4-10
 AC 9.21.4(c) Notifying and reporting about heliport conditions.....2-4-10
 AC 9.21.9 Notifying and reporting about heliport conditions.....2-4-10
 AC 9.23 Apron management service2-4-11

CHAPTER 10 LICENSING PROCESS

AC 10.1 Licensing process2-2-1
 AC 10.1.7 Key personnel.....2-2-1
 AC 10.1.8 Safety management systems.....2-2-2



This Page Intentionally Left Blank



CHAPTER 1

GENERAL

1.1 Applicability

- 1.1.1 CAR AGA 2 applies to heliports located in the territory of The Bahamas that are capable of meeting the requirements of these regulations, for the following operation of helicopters;
- (a) The conduct of international operations with any type of helicopter having a passenger seating configuration, excluding any pilot seats, of more than 5;
 - (b) The conduct of domestic commercial operations with any type of helicopter having a maximum take-off mass (MTOM) of 3 175 kg or more;
- 1.1.2 CAR AGA 2 also applies to the aerodrome service providers, rescue and firefighting services, security agencies, technical support companies for aircraft: dispatch, online service, fuelling, food and beverage supply, handling of cargo operation and other organisations which perform or may perform independent activities at the heliport.
- 1.1.3 A person shall not operate a heliport used for the purposes stated in 1.1.1 (a) or (b) unless it is certified in accordance with these regulations.
- 1.1.4 A person shall not operate a helicopter on operations stated in 1.1.1 (a) or (b) from any heliport unless it is certified in accordance with these regulations.
- 1.1.5 CAR AGA 2 shall also apply to heliports licensed under section 1.13.

1.2 General

- 1.2.1 The dimensions discussed in these regulations are based on consideration of single-main-rotor helicopters.
- 1.2.2 For tandem-rotor helicopters the heliport design will be based on a case-by-case review of the specific models using the basic requirement for a safety area and protection areas specified in this regulation.
- 1.2.3 The specifications of Chapter 3 are applicable for visual heliports that may or may not incorporate the use of a point-in-space approach or departure.
- Note: Additional specifications for instrument heliports with non-precision and/or precision approaches and instrument departures are detailed in the Appendix to ICAO Annex 14, Volume II.*
- 1.2.4 The specifications of these regulations are not applicable for water heliports (touchdown or lift-off on the surface of the water).
- 1.2.5 The interpretation of some of the specifications in these regulations expressly requires the exercising of discretion, the making of a decision or the performance of a function by the Authority. In other specifications, the expression Authority does not actually appear although its inclusion is implied. In both cases, the responsibility for whatever determination or action is necessary shall rest with the Authority having jurisdiction over the heliport.



- 1.2.6 The specifications in these regulations shall apply to all heliports intended to be used on operations stated in 1.1.1 (a) or (b). They shall apply equally to areas for the exclusive use of helicopters at an aerodrome primarily meant for the use of aeroplanes. Where relevant, the provisions of CAR AGA 1 shall apply to the helicopter operations being conducted at such an aerodrome.
- 1.2.7 Unless otherwise specified, the specification for a colour referred to within this regulation shall be that contained in Appendix 1 to ICAO Annex 14, Volume I.

Note 1: CAR AGA 2 contains regulations that prescribe the physical characteristics and obstacle limitation surfaces to be provided for at heliports, and certain facilities and technical services normally provided at a heliport.

Note 2: It is to be noted that provisions for helicopter flight operations are contained in Civil Aviation Regulations – Operations General Aviation – Helicopters (CAR OPS 2H) for private operations and Civil Aviation Regulations – Commercial Air Transportation - Helicopters (CAR OPS 3) for commercial air transport operations.

1.3 Requirements for registration of a heliport

All locations within the Bahamas used for the take-off and landing of helicopters shall be registered with the Authority. The heliport operator shall formally notify the Authority and provide the following minimum registration requirements:

- (a) The name of the heliport;
- (b) The location of the heliport including the geographical coordinates of the heliport;
- (c) The owner and operator of the heliport;
- (d) The types of helicopters operating; and
- (e) A description of the main activities carried out at the heliport.

1.4 Heliport operator responsibilities

- 1.4.1 The following heliport operator responsibilities shall be applicable to all heliports that conduct commercial passenger, cargo and mail operations within the Bahamas:
- (a) Movement area maintenance programs and plan for paved areas, unpaved areas, visual aids, electrical systems (as applicable), secondary power supply (as applicable.);
 - (b) aeronautical studies and risk assessment;
 - (c) safety audits and inspections by the Authority;
 - (d) apron management and safety;
 - (e) handling and storage of hazardous materials;
 - (f) vehicle operations (as applicable);
 - (g) obstacle control;



- (h) fencing;
- (i) notifying and reporting heliport conditions to the pilots;
- (j) safety during construction or maintenance;
- (k) ground servicing of helicopters;
- (l) disabled heliport removal;
- (m) heliport incident reporting and investigation; and
- (n) any other provision that in the opinion of the Authority is applicable to the heliport, commensurate with the heliport operations.

1.5 Definitions, abbreviations and symbols

- (a) Unless otherwise stated, applicable CAR DEF definitions are used throughout this document.
- (b) In addition to the following, applicable CAR DEF abbreviations are used throughout this document.

APAPI	Abbreviated precision approach path indicator
ASPSL	Arrays of segmented point source lighting
cd	Candela
cm	Centimetre
FATO	Final approach and take-off area
ft	Foot
GNSS	Global navigation satellite system
HAPI	Helicopter approach path indicator
HFM	Helicopter flight manual
Hz	Hertz
kg	Kilogram
km/h	Kilometre per hour
kt	Knot
L	Litre
lb	Pounds



LDAH	Landing distance available
L/min	Litre per minute
LOA	Limited obstacle area
LOS	Limited obstacle sector
LP	Luminescent panel
m	Metre
MAPt	Missed approach point
MTOM	Maximum take-off mass
OFS	Obstacle-free sector
PAPI	Precision approach path indicator
PinS	Point-in-space
R/T	Radiotelephony or radio communications
RTODAH	Rejected take-off distance available
s	Second
t	Tonne (1 000 kg)
TLOF	Touchdown and lift-off area
TODAH	Take-off distance available
UCW	Undercarriage width
VSS	Visual segment surface

(c) The following symbols are used throughout this document.

°	-	Degree
=	-	Equals
'	-	Minute of arc
μ	-	Friction coefficient
>	-	Greater than
<	-	Less than
%	-	Percentage
±	-	Plus or minus



1.6 Operational Coordination with Service Providers

- 1.6.1 The heliport operator shall coordinate with Air Traffic Services, Meteorological Services, Aeronautical Information Services, Rescue and Firefighting Services, Aviation Security Agencies, Customs, Immigration office and all other relevant services to ensure safety, availability and continuity on the provision of such services.
- 1.6.2 All Service Providers shall actively adhere to the heliport Safety Management System (SMS).
- 1.6.3 The heliport operator shall chair and lead as a minimum, the following committees:
- (a) The Safety Management Committee.
 - (b) The Security and Facilitation Committee.
 - (c) The Emergency Planning Committee,
 - (d) The Wildlife Hazard Control Committee
- 1.6.4 The heliport operator shall enter into Service Level Agreements with the heliport users and service providers with the aim of agreeing competences, liabilities or any other aspect needed to ensure heliport safety, availability and continuity of service provision. (See AC 1.6.4)
- 1.6.5 The heliport operator shall make arrangements with the Aeronautical Information Services provider for immediate notification to ensure that the appropriate parties receive the necessary data to provide updated information prior to the flight and satisfy the need of information during the flight, including;
- (a) information on the heliport certification situation and the heliport conditions;
 - (b) serviceability of the facilities, services and navigation aids located within the area of competence;
 - (c) any information that may be relevant to operations.
- 1.6.6 To ensure that Aeronautical Information Services units obtain information to enable them to provide up-to-date pre-flight information and to meet the need for in-flight information, arrangements shall be made between Aeronautical Information Services and heliport authorities responsible for heliport services to report the following to the responsible Aeronautical Information Services unit, with a minimum of delay.
- (a) Information on the status of certification of heliport and heliport conditions.
 - (b) the operational status of associated facilities, services and navigation aids within their area of responsibility;
 - (c) any other information considered to be of operational significance.
- 1.6.7 Before introducing changes to the air navigation system, due account shall be taken by the services responsible for such changes of the time needed by Aeronautical Information Services for the preparation, production and issue of relevant material for promulgation.



Note: To ensure timely provision of the information to Aeronautical Information Services, close coordination between those services concerned is required. Of a particular importance are changes to aeronautical information that affect charts and/or computer-based navigation systems which qualify to be notified by the Aeronautical Information Regulation And Control (AIRAC) system, as specified in CAR AIS, (Aeronautical Information Services)

- 1.6.8 The predetermined, internationally agreed AIRAC effective dates in addition to 14 days postage time shall be observed by the responsible heliport services when submitting the raw information/data to Aeronautical Information Services.
- 1.6.9 The heliport services responsible for the provision of raw aeronautical information/data to the Aeronautical Information Services shall ensure accuracy and integrity requirements for aeronautical data as specified in CAR AIS.

1.7 Access to the heliport

- 1.7.1 A person authorised by the Authority may verify, audit, inspect and carry out tests on the heliport facilities, services and equipment, inspect the heliport operator's documents and records and audit the heliport operator's SMS before the heliport certificate is granted or renewed and subsequently, at any other time, for the purpose of ensuring safety at the heliport.
- 1.7.2 A heliport operator or applicant shall, at the request of the Authority's authorised person cooperate in the inspection duties and allow access to any part of the heliport or any heliport facility, including equipment, technical records and documents as well as operator and management personnel.
- 1.7.3 The heliport operator shall observe and comply with the annual monitoring programme established by the Authority for safety monitoring purposes at each heliport. This shall not affect random unannounced inspections or audits conducted by an authorised person to determine whether approved operation requirements and procedures are met under all circumstances and whether they conform to the activity and comply with these regulations.
- 1.7.4 The heliport operator shall resolve the findings from the Authority's authorised person(s) and once notified by an official report, shall send a corrective action plan within the established period.
- 1.7.5 Failure to resolve the findings may result in the revocation/suspension of the heliport certificate and/or enforcement consequences.

1.8 Aeronautical Studies

(See AC 1.8)

- 1.8.1 An aeronautical study shall be conducted to assess the impact of deviations from the heliport standards specified in these regulations to present alternative means of ensuring the safety of helicopter operations, to estimate the effectiveness of each alternative and to recommend procedures to compensate for the deviation.

1.9 Operational Directives

- 1.9.1 The Authority may issue operational directives to prohibit, limit or subject an operation to certain conditions in the interest of safety.
- 1.9.2 Operational directives shall have:
- (a) The reason for issuance;



- (b) The scope and duration; and
- (c) Action required from heliport operators.

1.9.3 Anything required by the operational directives shall be considered an additional requirement to those established in these regulations

1.9.4 The Authority may also issue Acceptable Means of Compliance to facilitate compliance and implementation of this regulation.

1.10 Common reference systems

1.10.1 Horizontal reference system

World Geodetic System — 1984 (WGS-84) shall be used as the horizontal (geodetic) reference system. Reported aeronautical geographical coordinates (indicating latitude and longitude) shall be expressed in terms of the WGS-84 geodetic reference datum.

1.10.2 Vertical reference system

Mean sea level (MSL) datum, which gives the relationship of gravity-related height (elevation) to a surface known as the geoid, shall be used as the vertical reference system.

1.10.3 Temporal reference system

- (a) The Gregorian calendar and Coordinated Universal Time (UTC) shall be used as the temporal reference system.
- (b) When a different temporal reference system is used, this shall be indicated in GEN 2.1.2 of the Aeronautical Information Publication (AIP) of The Bahamas.

1.11 Certification of heliports

(See AC 1.11)

1.11.1 The Authority shall certify heliports in accordance with the specifications contained in these regulations as well as other relevant ICAO specifications through an appropriate regulatory framework.

1.11.2 The Authority shall certify heliports open to public use in accordance with these specifications as well as other relevant ICAO specifications through an appropriate regulatory framework.

1.11.3 The regulatory framework shall include the establishment of criteria and procedures for the certification of heliports.

1.11.4 As part of the certification process, the Authority shall ensure that a heliport manual which will include all pertinent information on the heliport site, facilities, services, equipment, operating procedures, organization and management including a safety management system, is submitted by the applicant for approval/acceptance prior to granting the heliport certificate.



1.12 Heliport design

1.12.1 Architectural and infrastructure-related requirements for the optimum implementation of international civil aviation security measures shall be integrated into the design and construction of new facilities and alterations to existing facilities at a heliport.

1.12.2 The design of heliports shall take into account land-use and environmental control measures.

1.13 Licensing of heliports

(See AC 1.13)

1.13.1 A heliport, other than a certified heliport, that is incapable of being certified, shall be licenced in accordance with Chapter 10 when used for the following purposes;

- (1) international operations with any type of helicopter having a passenger seating configuration, excluding any pilot seats, of 5 or less;
- (2) domestic commercial operations with any type of helicopter having a maximum take-off mass (MTOM) of less than 3 175 kg;
- (3) domestic general aviation operations from public use heliports;
- (4) night operations.

Note: Heliports not for public use must be registered but need not be licensed.

1.13.2 Unless exempted from any regulation, a licensed heliport shall comply with the physical specifications of these regulations.

1.13.3 A person shall not operate a heliport used for the purposes stated in 1.13.1 unless it is certified or licensed in accordance with these regulations.

1.13.4 A person shall not operate a helicopter on operations stated in 1.13.1 from any heliport unless it is certified or licensed in accordance with these regulations.



CHAPTER 2

HELIPORT DATA

2.1 Aeronautical data

- 2.1.1 Determination and reporting of heliport-related aeronautical data shall be in accordance with the accuracy and integrity classification required to meet the needs of the end-user of aeronautical data.
- 2.1.2 Digital data error detection techniques shall be used during the transmission and/or storage of aeronautical data and digital data sets.

2.2 Heliport reference point

- 2.2.1 A heliport reference point shall be established for a heliport or a landing location not collocated with an aerodrome.
- 2.2.2 The heliport reference point shall be located near the initial or planned geometric centre of the heliport and shall normally remain where first established.
- 2.2.3 The position of the heliport reference point shall be measured and reported to the aeronautical information services authority in degrees, minutes and seconds.

2.3 Heliport elevations

- 2.3.1 The heliport elevation and geoid undulation at the heliport elevation position shall be measured and reported to the aeronautical information services authority to the accuracy of one-half metre or foot.
- 2.3.2 The elevation of the TLOF and/or the elevation and geoid undulation of each threshold of the FATO (where appropriate) shall be measured and reported to the aeronautical information services authority to the accuracy of one-half metre or foot.

2.4 Heliport dimensions and related information

- 2.4.1 The following data shall be measured or described, as appropriate, for each facility provided on a heliport:
 - (a) heliport type — surface-level, elevated, shipboard or helideck;
 - (b) TLOF — dimensions to the nearest metre or foot, slope, surface type, bearing strength in tonnes (1 000 kg);
 - (c) FATO — type of FATO, true bearing to one-hundredth of a degree, designation number (where appropriate), length and width to the nearest metre or foot, slope, surface type;
 - (d) safety area — length, width and surface type;
 - (e) helicopter taxiway and helicopter taxi route — designation, width, surface type;
 - (f) apron — surface type, helicopter stands;



- (g) clearway — length, ground profile; and
- (h) visual aids for approach procedures, marking and lighting of FATO, TLOF, helicopter ground taxiways, helicopter air taxiways and helicopter stands.

2.4.2 The geographical coordinates of the geometric centre of the TLOF and/or of each threshold of the FATO (where appropriate) shall be measured and reported to the aeronautical information services authority in degrees, minutes, seconds and hundredths of seconds.

2.4.3 The geographical coordinates of appropriate centre line points of helicopter taxiways and helicopter taxi routes shall be measured and reported to the aeronautical information services authority in degrees, minutes, seconds and hundredths of seconds.

2.4.4 The geographical coordinates of each helicopter stand shall be measured and reported to the aeronautical information services authority in degrees, minutes, seconds and hundredths of seconds.

2.4.5 The geographical coordinates of obstacles in Area 2 (the part within the heliport boundary) and in Area 3 shall be measured and reported to the aeronautical information services authority in degrees, minutes, seconds and tenths of seconds. In addition, the top elevation, type, marking and lighting (if any) of obstacles shall be reported to the aeronautical information services authority.

2.5 Declared distances

The following distances to the nearest metre or foot shall be declared, where relevant, for a heliport:

- (a) take-off distance available;
- (b) rejected take-off distance available; and
- (c) landing distance available.

2.6 Coordination between aeronautical information services and heliport authorities

2.6.1 To ensure that aeronautical information services units obtain information to enable them to provide up-to-date pr5-light information and to meet the need for in-flight information, arrangements shall be made between aeronautical information services and heliport authorities responsible for heliport services to report to the responsible aeronautical information services unit, with a minimum of delay:

- (a) information on heliport conditions;
- (b) the operational status of associated facilities, services and navigation aids within their area of responsibility;
- (c) any other information considered to be of operational significance.

2.6.2 Before introducing changes to the air navigation system, due account shall be taken by the services responsible for such changes of the time needed by the aeronautical information service for the preparation, production and issue of relevant material for promulgation. To ensure timely provision of the information to the aeronautical information service, close coordination between those services concerned is therefore required.



2.6.3 Of a particular importance are changes to aeronautical information that affect charts and/or computer-based navigation systems which qualify to be notified by the Aeronautical Information Regulation And Control (AIRAC) system, as specified in Annex 15, Chapter 6 and Appendix 4. The predetermined, internationally agreed AIRAC effective dates in addition to 14 days postage time shall be observed by the responsible heliport services when submitting the raw information/data to Aeronautical Information Services.

2.6.4 The heliport services responsible for the provision of raw aeronautical information/data to the Aeronautical Information Services shall do that while taking into account accuracy and integrity requirements for aeronautical data as specified in Appendix 1 to ICAO Annex 14, Volume II.

2.7 Rescue and firefighting

2.7.1 Information concerning the level of protection provided at a heliport for helicopter rescue and firefighting purposes shall be made available.

2.7.2 The level of protection normally available at a heliport should be expressed in terms of the category of the rescue and firefighting service as described in 6.2 and in accordance with the types and amounts of extinguishing agents normally available at the heliport.

2.7.3 Changes in the level of protection normally available at a heliport for rescue and firefighting shall be notified to the appropriate aeronautical information services units and, where applicable, air traffic units to enable them to provide the necessary information to arriving and departing helicopters. When such a change has been corrected, the above units shall be advised accordingly.

Note. — Changes in the level of protection from that normally available at the heliport could result from, but may not be limited to, a change in the availability of extinguishing agent or equipment used to deliver agents, or of personnel used to operate the equipment.

2.7.4 A change should be expressed in terms of the new category of the rescue and firefighting service available at the heliport.



This Page Intentionally Left Blank



CHAPTER 3

PHYSICAL CHARACTERISTICS

3.1 Surface-level heliports

Final approach and take-off areas

3.1.1 A surface-level heliport shall be provided with at least one final approach and take-off area (FATO).

3.1.2 A FATO shall be obstacle free.

3.1.3 The dimensions of a FATO shall be:

- (a) where intended to be used by helicopters operated in performance class 1, as prescribed in the Helicopter Flight Manual (HFM) except that, in the absence of width specifications, the width shall be not less than the greatest overall dimension (D) of the largest helicopter the FATO is intended to serve;
- (b) where intended to be used by helicopters operated in performance class 2 or 3, of sufficient size and shape to contain an area within which can be drawn a circle of diameter not less than:
 - (1) 1 D of the largest helicopter when the maximum take-off mass (MTOM) of helicopters the FATO is intended to serve is more than 3 175 kg;
 - (2) 0.83 D of the largest helicopter when the MTOM of helicopters the FATO is intended to serve is 3 175 kg or less.

Note: The term FATO is not used in the HFM. The minimum landing/take-off area specified in the HFM for the appropriate performance class 1 flight profile is necessary to determine the size of the FATO. However, for vertical take-off procedures in performance class 1, the required rejected take-off area is not normally quoted in the HFM, and it will be necessary to obtain information which includes complete containment — this figure will always be greater than 1 D.

3.1.4 Where intended to be used by helicopters operated in performance class 2 or 3 with MTOM of 3 175 kg or less, the FATO shall be of sufficient size and shape to contain an area within which can be drawn a circle of diameter not less than 1 D.

3.1.5 The FATO shall provide rapid drainage but the mean slope in any direction shall not exceed 3 per cent. No portion of a FATO shall have a local slope exceeding:

- (a) per cent where the heliport is intended to be used by helicopters operated in performance class 1; and
- (b) 7 per cent where the heliport is intended to be used by helicopters operated in performance class 2 or 3.

3.1.6 The surface of the FATO shall:

- (a) be resistant to the effects of rotor downwash;
- (b) be free of irregularities that would adversely affect the take-off or landing of helicopters; and
- (c) have bearing strength sufficient to accommodate a rejected take-off by helicopters operated in performance class 1.

3.1.7 The surface of a FATO surrounding a touchdown and lift-off area (TLOF) intended for use by helicopters operated in performance classes 2 and 3 shall be static load-bearing.

3.1.8 The FATO shall provide ground effect.

3.1.9 The FATO shall be located so as to minimize the influence of the surrounding environment, including turbulence, which could have an adverse impact on helicopter operations.

Helicopter clearways

Note: A helicopter clearway would need to be considered when the heliport is intended to be used by helicopters operating in performance class 1. See the Heliport Manual (Doc 9261).

3.1.10 When a helicopter clearway is provided, it shall be located beyond the end of the FATO.

3.1.11 The width of a helicopter clearway shall not be less than that of the associated safety area. (See Figure 3-1.)

3.1.12 The ground in a helicopter clearway shall not project above a plane having an upward slope of 3 per cent, the lower limit of this plane being a horizontal line which is located on the periphery of the FATO.

3.1.13 An object situated in a helicopter clearway, which may endanger helicopters in the air, shall be regarded as an obstacle and shall be removed.

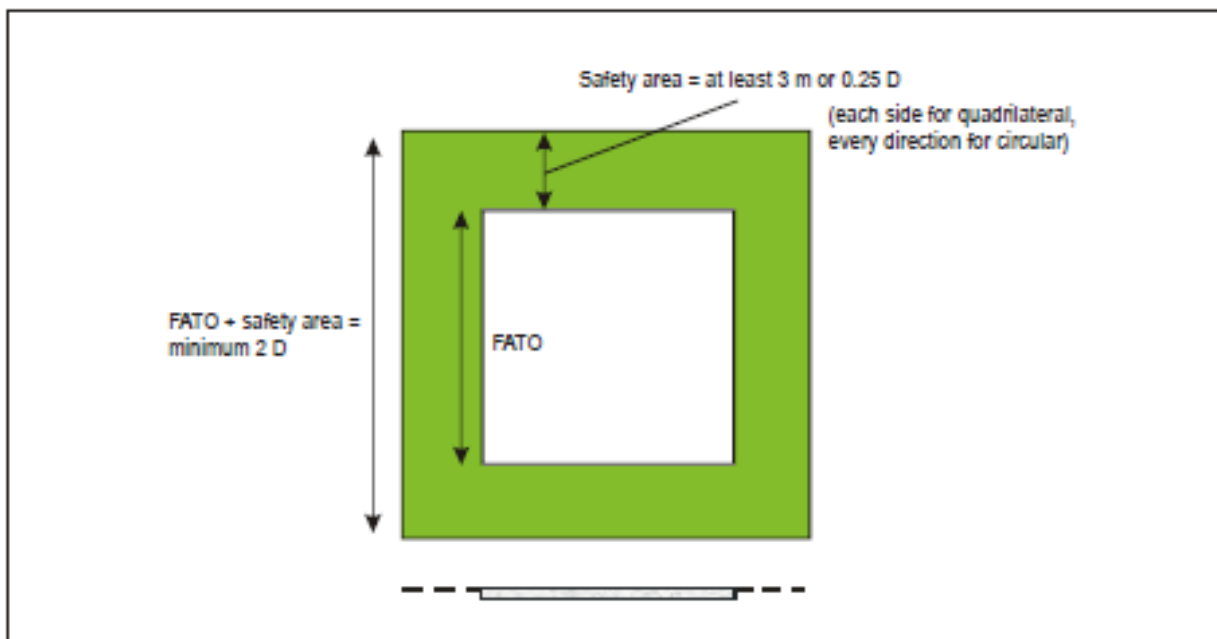

Figure 3-1. FATO and associated safety area



Touchdown and lift-off areas

- 3.1.14 At least one TLOF, being either circular, square or octagonal, shall be provided at a heliport.
- 3.1.15 One TLOF shall be located within the FATO or one or more TLOFs shall be collocated with helicopter stands. For runway-type FATOs, additional TLOFs located in the FATO are acceptable.
- 3.1.16 TLOF shall be of sufficient size to contain a circle of diameter of at least 0.83 D of the largest helicopter the area is intended to serve.
- 3.1.17 Slopes on a TLOF shall be sufficient to prevent accumulation of water on the surface of the area, but shall not exceed 2 per cent in any direction.
- 3.1.18 Where the TLOF is within the FATO, the TLOF shall be dynamic load-bearing.
- 3.1.19 Where a TLOF is collocated with a helicopter stand, the TLOF shall be static load-bearing and be capable of withstanding the traffic of helicopters that the area is intended to serve.
- 3.1.20 Where a TLOF is located within a FATO which can contain a circle of diameter more than 1 D, the centre of the TLOF shall be located not less than 0.5 D from the edge of the FATO.

Safety areas

- 3.1.21 A FATO shall be surrounded by a safety area which need not be solid.
- 3.1.22 A safety area surrounding a FATO shall extend outwards from the periphery of the FATO for a distance of at least 3 m or 0.25 D, whichever is greater, of the largest helicopter the FATO is intended to serve and:
- (a) each external side of the safety area shall be at least 2 D where the FATO is quadrilateral; or
 - (b) the outer diameter of the safety area shall be at least 2 D where the FATO is circular. (See Figure 3-1.)
- 3.1.23 There shall be a protected side slope rising at 45 degrees from the edge of the safety area to a distance of 10 m, whose surface shall not be penetrated by obstacles, except that when obstacles are located to one side of the FATO only, they may be permitted to penetrate the side slope surface.
- 3.1.24 No fixed object shall be permitted above the plane of the FATO on a safety area, except for frangible objects, which, because of their function, must be located on the area. No mobile object shall be permitted on a safety area during helicopter operations.
- 3.1.25 Objects whose function requires them to be located on the safety area shall not:
- (a) if located at a distance of less than 0.75 D from the centre of the FATO, penetrate a plane at a height of 5 cm above the plane of the FATO; and
 - (b) if located at a distance of 0.75 D or more from the centre of the FATO, penetrate a plane originating at a height of 25 cm above the plane of the FATO and sloping upwards and outwards at a gradient of 5 percent.

- 3.1.26 The surface of the safety area, when solid, shall not exceed an upward slope of 4 per cent outwards from the edge of the FATO.
- 3.1.27 Where applicable, the surface of the safety area shall be treated to prevent flying debris caused by rotor downwash.
- 3.1.28 When solid, the surface of the safety area abutting the FATO shall be continuous with the FATO.

Helicopter ground taxiways and helicopter ground taxi-routes

Note 1: A helicopter ground taxiway is intended to permit the surface movement of a wheeled helicopter under its own power.

Note 2: When a taxiway is intended for use by aeroplanes and helicopters, the provisions for taxiways for aeroplanes and helicopter ground taxiways will be taken into consideration and the more stringent requirements will be applied.

- 3.1.29 The width of a helicopter ground taxiway shall not be less than 1.5 times the largest width of the undercarriage (UCW) of the helicopters the helicopter ground taxiway is intended to serve. (See Figure 3-2.)
- 3.1.30 The longitudinal slope of a helicopter ground taxiway shall not exceed 3 per cent.

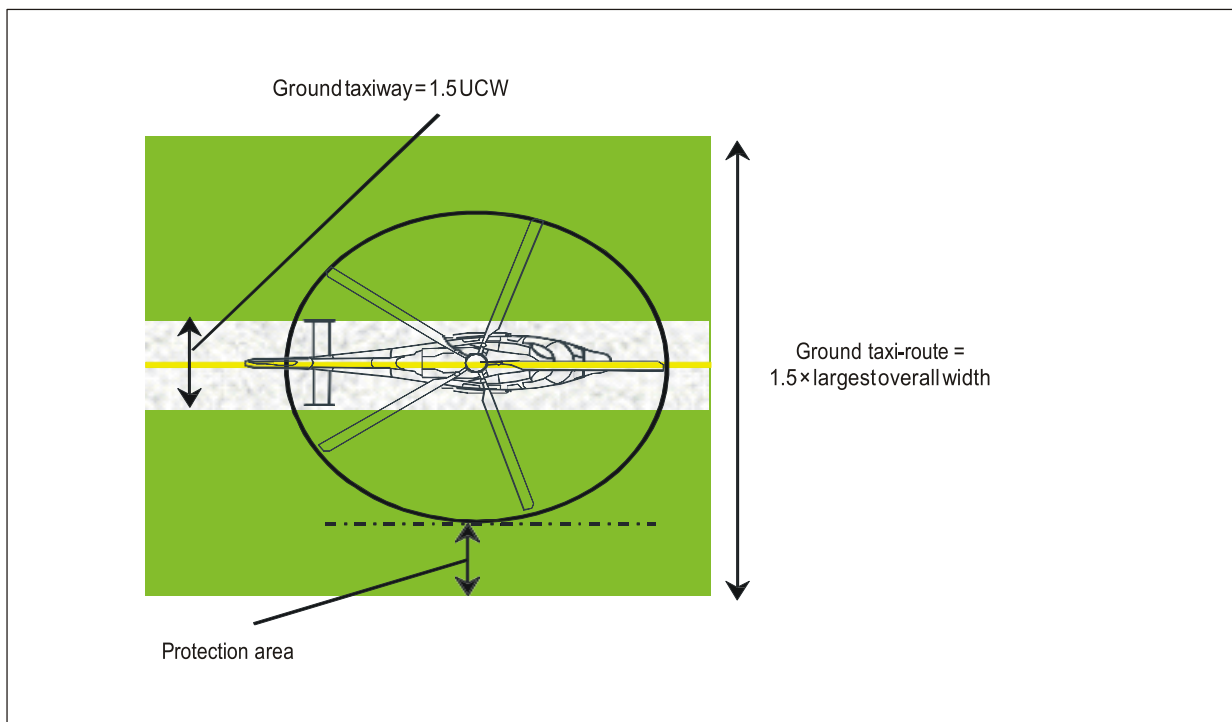

Figure 3-2. Helicopter ground taxi-route/taxiway

- 3.1.31 A helicopter ground taxiway shall be static load-bearing and be capable of withstanding the traffic of the helicopters the helicopter ground taxiway is intended to serve.
- 3.1.32 A helicopter ground taxiway shall be centred on a ground taxi-route.
- 3.1.33 A helicopter ground taxi-route shall extend symmetrically on each side of the centre line for at least 0.75 times the largest overall width of the helicopters it is intended to serve.



- 3.1.34 No fixed object shall be permitted above the surface of the ground on a helicopter ground taxi-route, except for frangible objects, which, because of their function, must be located thereon. No mobile object shall be permitted on a ground taxi-route during helicopter movements.
- 3.1.35 Objects whose function requires them to be located on a helicopter ground taxi-route shall not:
- (a) be located at a distance of less than 50 cm from the edge of the helicopter ground taxiway; and
 - (b) penetrate a plane originating at a height of 25 cm above the plane of the helicopter ground taxiway, at a distance of 50 cm from the edge of the helicopter ground taxiway and sloping upwards and outwards at a gradient of 5 per cent.
- 3.1.36 The helicopter ground taxiway and the helicopter ground taxi-route shall provide rapid drainage but the helicopter ground taxiway transverse slope shall not exceed 2 per cent.
- 3.1.37 The surface of a helicopter ground taxi-route shall be resistant to the effect of rotor downwash.
- 3.1.38 For simultaneous operations, the helicopter ground taxi-routes shall not overlap.

Helicopter air taxiways and helicopter air taxi-routes

Note: A helicopter air taxiway is intended to permit the movement of a helicopter above the surface at a height normally associated with ground effect and at ground speed less than 37km/h (20 kt).

- 3.1.39 The width of a helicopter air taxiway shall be at least two times the largest undercarriage width (UCW) of the helicopters that the helicopter air taxiway is intended to serve. (See Figure 3-3.)
- 3.1.40 The surface of a helicopter air taxiway shall be static load-bearing.
- 3.1.41 The slopes of the surface of a helicopter air taxiway shall not exceed the slope landing limitations of the helicopters the helicopter air taxiway is intended to serve. In any event the transverse slope shall not exceed 10 per cent and the longitudinal slope shall not exceed 7 per cent.
- 3.1.42 A helicopter air taxiway shall be centred on an air taxi-route.
- 3.1.43 A helicopter air taxi-route shall extend symmetrically on each side of the centre line for a distance at least equal to the largest overall width of the helicopters it is intended to serve.
- 3.1.44 No fixed object shall be permitted above the surface of the ground on an air taxi-route, except for frangible objects, which, because of their function, must be located thereon. No mobile object shall be permitted on an air taxi-route during helicopter movements.

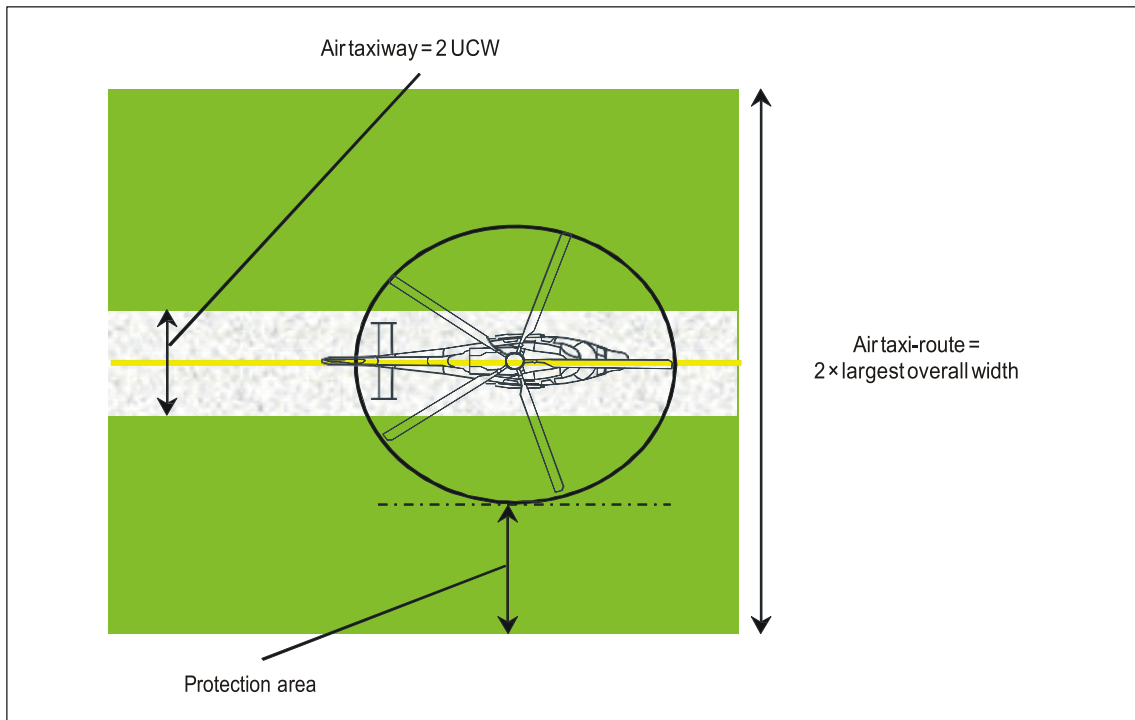

Figure 3-3. Helicopter air taxi-route/taxiway

3.1.45 Objects above ground level whose function requires them to be located on a helicopter air taxi-route shall not:

- (a) be located at a distance of less than 1 m from the edge of the helicopter air taxiway; and
- (b) penetrate a plane originating at a height of 25 cm above the plane of the helicopter air taxiway, at a distance of 1 m from the edge of the helicopter air taxiway and sloping upwards and outwards at a gradient of 5 per cent.

3.1.46 Objects above ground level whose function requires them to be located on a helicopter air taxi-route should not:

- (a) be located at a distance of less than 0.5 times the largest overall width of the helicopter for which the helicopter air taxi-route is designed from the centre line of the helicopter air taxiway; and
- (b) penetrate a plane originating at a height of 25 cm above the plane of the helicopter air taxiway, at a distance of 0.5 times the largest overall width of the helicopter for which the helicopter air taxi-route is designed from the centre line of the helicopter air taxiway, and sloping upwards and outwards at a gradient of 5 per cent.

3.1.47 The surface of a helicopter air taxi-route shall be resistant to the effect of rotor downwash.

3.1.48 The surface of a helicopter air taxi-route shall provide ground effect.

3.1.49 For simultaneous operations, the helicopter air taxi-routes shall not overlap.

Helicopter stands

3.1.50 When a TLOF is collocated with a helicopter stand, the protection area of the stand shall not overlap the protection area of any other helicopter stand or associated taxi route.

- 3.1.51 The helicopter stand shall provide rapid drainage but the slope in any direction shall not exceed 2 per cent.
- 3.1.52 A helicopter stand intended to be used by helicopters turning in a hover shall be of sufficient size to contain a circle of diameter of at least 1.2 D of the largest helicopter the stand is intended to serve. (See Figure 3-4.)
- 3.1.53 Where a helicopter stand is intended to be used for taxi-through and where the helicopter using the stand is not required to turn, the minimum width of the stand and associated protection area shall be that of the taxi-route.
- 3.1.54 Where a helicopter stand is intended to be used for turning, the minimum dimension of the stand and protection area shall be not less than 2 D.
- 3.1.55 Where a helicopter stand is intended to be used for turning, it shall be surrounded by a protection area which extends for a distance of 0.4 D from the edge of the helicopter stand.

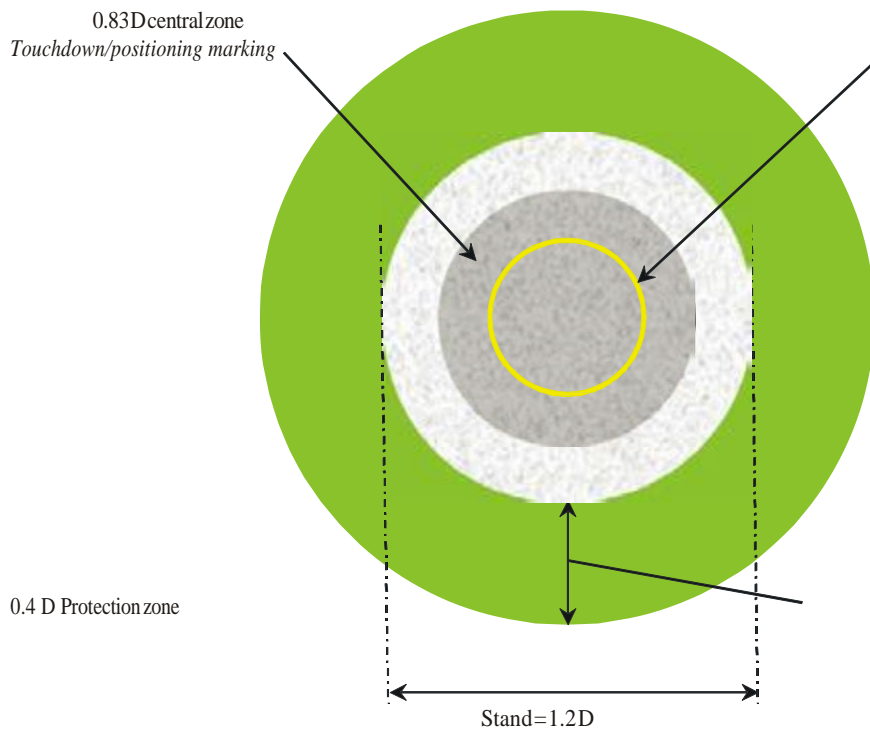

Figure 3-4. Helicopter stand and associated protection area

- 3.1.56 For simultaneous operations, the protection areas of helicopter stands and their associated taxi-routes shall not overlap. (See Figure 3-5.)
- 3.1.57 A helicopter stand and associated protection area intended to be used for air taxiing shall provide ground effect.
- 3.1.58 No fixed object shall be permitted above the surface of the ground on a helicopter stand.
- 3.1.59 No fixed object shall be permitted above the surface of the ground in the protection area around a helicopter stand except for frangible objects, which because of their function, must be located there.
- 3.1.60 No mobile object shall be permitted on a helicopter stand and the associated protection area during helicopter movements.

3.1.61 Objects whose function requires them to be located in the protection area shall not:

- (a) if located at a distance of less than 0.75 D from the centre of the helicopter stand, penetrate a plane at a height of 5 cm above the plane of the central zone; and
- (b) if located at a distance of 0.75 D or more from the centre of the helicopter stand, penetrate a plane at a height of 25 cm above the plane of the central zone and sloping upwards and outwards at a gradient of 5 per cent.

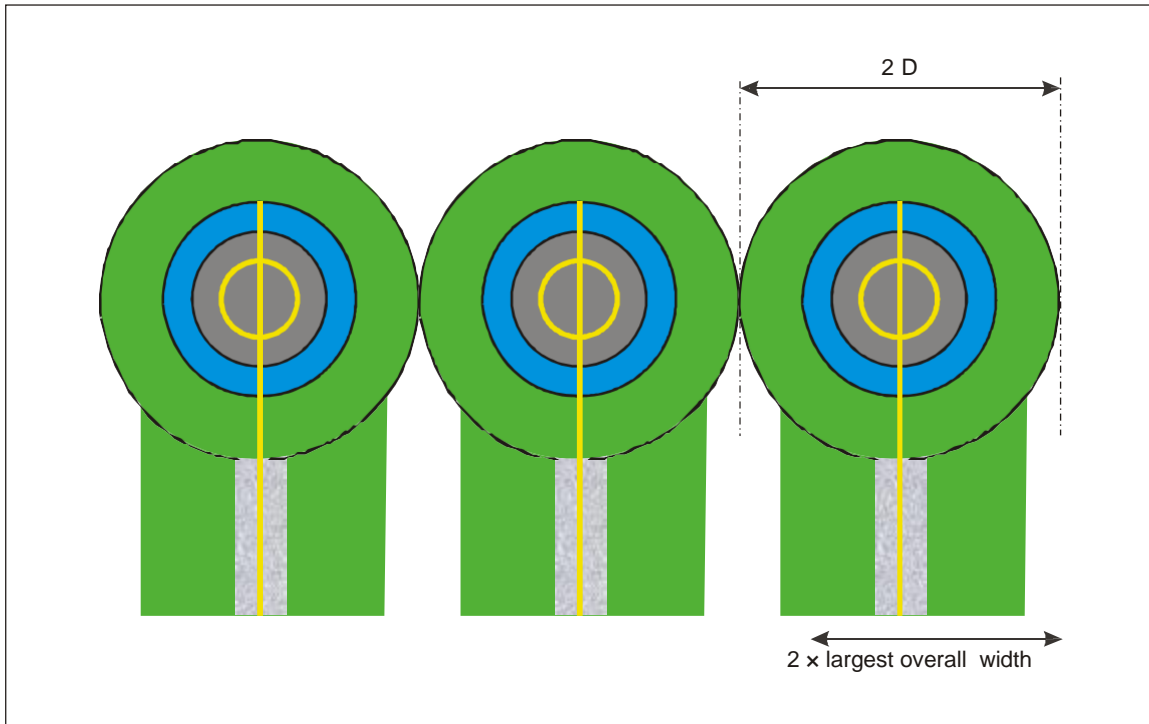

Figure 3-5. Helicopter stands designed for hover turns with air taxi-routes/taxiways — simultaneous operations

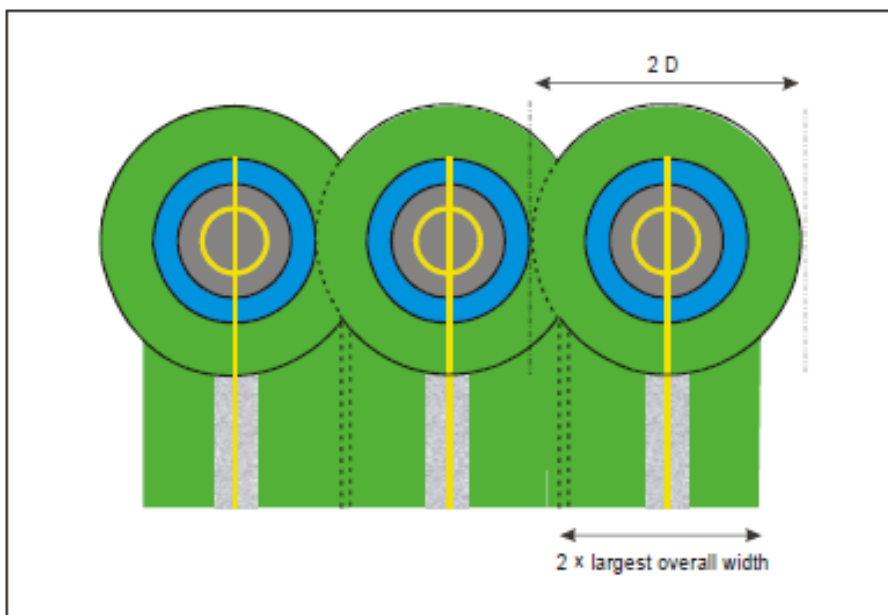

Figure 3-6. Helicopter stands designed for hover turns with air taxi-routes/taxiways — non-simultaneous operations



3.1.62 The central zone of a helicopter stand shall be capable of withstanding the traffic of helicopters it is intended to serve and have a static load-bearing area:

- (a) of diameter not less than 0.83 D of the largest helicopter it is intended to serve; or
- (b) for a helicopter stand intended to be used for taxi-through, and where the helicopter using the stand is not required to turn, the same width as the helicopter ground taxiway.

Location of a final approach and take-off area in relation to a runway or taxiway

3.1.63 Where a FATO is located near a runway or taxiway, and where simultaneous operations are planned, the separation distance between the edge of a runway or taxiway and the edge of a FATO shall not be less than the appropriate dimension in Table 3-1.

3.1.64 A FATO shall not be located:

- (a) near taxiway intersections or holding points where jet engine efflux is likely to cause high turbulence; or
- (b) near areas where aeroplane vortex wake generation is likely to exist.

3.2 Elevated heliports

3.2.1 In the case of elevated heliports, design considerations of the different elements of the heliport shall take into account additional loading resulting from the presence of personnel, snow, freight, refuelling, firefighting equipment, etc.

Table 3-1. FATO minimum separation distance

If aeroplane mass and/or helicopter mass are	Distance between FATO edge and runway edge or taxiway edge
up to but not including 3 175 kg	60 m
3 175 kg up to but not including 5 760 kg	120 m
5 760 kg up to but not including 100 000 kg	180 m
100 000 kg and over	250 m

Final approach and take-off areas and touchdown and lift-off areas

Note: On elevated heliports it is presumed that the FATO and one TLOF will be coincidental.

3.2.2 An elevated heliport shall be provided with one FATO.

3.2.3 A FATO shall be obstacle free.

3.2.4 The dimensions of the FATO shall be:

- (a) where intended to be used by helicopters operated in performance class 1, as prescribed in the helicopter flight manual (HFM) except that, in the absence of width specifications, the width shall be not less than 1 D of the largest helicopter the FATO is intended to serve;



- (b) where intended to be used by helicopters operated in performance class 2 or 3, of sufficient size and shape to contain an area within which can be drawn a circle of diameter not less than:
- (1) 1 D of the largest helicopter when the MTOM of helicopters the FATO is intended to serve is more than 3 175 kg;
 - (2) 0.83 D of the largest helicopter when the MTOM of helicopters the FATO is intended to serve is 3 175 kg or less.

3.2.5 Where intended to be used by helicopters operated in performance class 2 or 3 with MTOM of 3 175 kg or less, the FATO shall be of sufficient size and shape to contain an area within which can be drawn a circle of diameter not less than 1 D.

3.2.6 Slopes on a FATO at an elevated heliport shall be sufficient to prevent accumulation of water on the surface of the area, but shall not exceed 2 per cent in any direction.

3.2.7 The FATO shall be dynamic load-bearing.

3.2.8 The surface of the FATO shall be:

- (a) resistant to the effects of rotor downwash; and
- (b) free of irregularities that would adversely affect the take-off or landing of helicopters.

3.2.9 The FATO shall provide ground effect.

Helicopter clearways

3.2.10 When a helicopter clearway is provided, it shall be located beyond the end of the rejected take-off area available.

3.2.11 The width of a helicopter clearway shall not be less than that of the associated safety area.

3.2.12 When solid, the surface of the helicopter clearway shall not project above a plane having an upward slope of 3 per cent, the lower limit of this plane being a horizontal line which is located on the periphery of the FATO.

3.2.13 An object situated on a helicopter clearway which may endanger helicopters in the air shall be regarded as an obstacle and shall be removed.

Touchdown and lift-off areas

3.2.14 One TLOF shall be coincidental with the FATO.

3.2.15 For a TLOF coincidental with the FATO, the dimensions and the characteristics of the TLOF shall be the same as those of the FATO.

3.2.16 When the TLOF is collocated with a helicopter stand, the TLOF shall be of sufficient size to contain a circle of diameter of at least 0.83 D of the largest helicopter the area is intended to serve.

3.2.17 Slopes on a TLOF collocated with a helicopter stand shall be sufficient to prevent accumulation of water on the surface of the area, but shall not exceed 2 per cent in any direction.



3.2.18 When the TLOF is collocated with a helicopter stand and intended to be used by ground taxiing helicopters only, the TLOF shall at least be static load-bearing and be capable of withstanding the traffic of the helicopters the area is intended to serve.

3.2.19 When the TLOF is collocated with a helicopter stand and intended to be used by air taxiing helicopters, the TLOF shall have a dynamic load-bearing area.

Safety areas

3.2.20 The FATO shall be surrounded by a safety area which need not be solid.

3.2.21 A safety area surrounding a FATO intended to be used by helicopters operated in performance class 1 in visual meteorological conditions (VMC) shall extend outwards from the periphery of the FATO for a distance of at least 3 m or 0.25 D, whichever is greater, of the largest helicopter the FATO is intended to serve and:

- (a) each external side of the safety area shall be at least 2 D where the FATO is quadrilateral;
or
- (b) the outer diameter of the safety area shall be at least 2 D where the FATO is circular.

3.2.22 A safety area surrounding a FATO intended to be used by helicopters operated in performance class 2 or 3 in visual meteorological conditions (VMC) shall extend outwards from the periphery of the FATO for a distance of at least 3 m or 0.5 D, whichever is the greater, of the largest helicopter the FATO is intended to serve and:

- (a) each external side of the safety area shall be at least 2 D where the FATO is quadrilateral;
or
- (b) the outer diameter of the safety area shall be at least 2 D where the FATO is circular.

3.2.23 There shall be a protected side slope rising at 45 degrees from the edge of the safety area to a distance of 10 m, whose surface shall not be penetrated by obstacles, except that when obstacles are located to one side of the FATO only, they may be permitted to penetrate the side slope surface.

3.2.24 No fixed object shall be permitted on a safety area, except for frangible objects, which, because of their function, must be located on the area. No mobile object shall be permitted on a safety area during helicopter operations.

3.2.25 Objects whose function require them to be located on the safety area shall not exceed a height of 25 cm when located along the edge of the FATO nor penetrate a plane originating at a height of 25 cm above the edge of the FATO and sloping upwards and outwards from the edge of the FATO at a gradient of 5 per cent.

3.2.26 In the case of a FATO of diameter less than 1 D, the maximum height of the objects whose functions require them to be located on the safety area should not exceed a height of 5 cm.

3.2.27 The surface of the safety area, when solid, shall not exceed an upward slope of 4 per cent outwards from the edge of the FATO.

3.2.28 Where applicable, the surface of the safety area shall be prepared in a manner to prevent flying debris caused by rotor downwash.



3.2.29 The surface of the safety area abutting the FATO shall be continuous with the FATO.

Helicopter ground taxiways and ground taxi-routes

3.2.30 The width of a helicopter ground taxiway shall not be less than 2 times the largest width of the undercarriage (UCW) of the helicopters the ground taxiway is intended to serve.

3.2.31 The longitudinal slope of a helicopter ground taxiway shall not exceed 3 per cent.

3.2.32 A helicopter ground taxiway shall be static load-bearing and be capable of withstanding the traffic of the helicopters the helicopter ground taxiway is intended to serve.

3.2.33 A helicopter ground taxiway shall be centred on a ground taxi-route.

3.2.34 A helicopter ground taxi-route shall extend symmetrically on each side of the centre line to a distance not less than the largest overall width of the helicopters it is intended to serve.

3.2.35 No objects shall be permitted on a helicopter ground taxi-route, except for frangible objects, which, because of their function, must be located there.

3.2.36 The helicopter ground taxiway and the ground taxi-route shall provide rapid drainage but the helicopter ground taxiway transverse slope shall not exceed 2 per cent.

3.2.37 The surface of a helicopter ground taxi-route shall be resistant to the effect of rotor downwash.

Helicopter air taxiways and air taxi-routes

Note: A helicopter air taxiway is intended to permit the movement of a helicopter above the surface at a height normally associated with ground effect and at ground speed less than 37 km/h (20 kt).

3.2.38 The width of a helicopter air taxiway shall be at least three times the largest width of the undercarriage (UCW) of the helicopters the air taxiway is intended to serve.

3.2.39 The surface of a helicopter air taxiway shall be dynamic load-bearing.

3.2.40 The transverse slope of the surface of a helicopter air taxiway shall not exceed 2 per cent and the longitudinal slope shall not exceed 7 per cent. In any event, the slopes shall not exceed the slope landing limitations of the helicopters the air taxiway is intended to serve.

3.2.41 A helicopter air taxiway shall be centred on an air taxi-route.

3.2.42 A helicopter air taxi-route shall extend symmetrically on each side of the centre line to a distance not less than the largest overall width of the helicopters it is intended to serve.

3.2.43 No objects shall be permitted on an air taxi-route, except for frangible objects, which, because of their function, must be located thereon.

3.2.44 The surface of an air taxi-route shall be resistant to the effect of rotor downwash.

3.2.45 The surface of an air taxi-route shall provide ground effect.



Aprons

- 3.2.46 The slope in any direction on a helicopter stand shall not exceed 2 per cent.
- 3.2.47 A helicopter stand shall be of sufficient size to contain a circle of diameter of at least 1.2 D of the largest helicopters the stand is intended to serve.
- 3.2.48 If a helicopter stand is used for taxi-through, the minimum width of the stand and associated protection area shall be that of the taxi-route.
- 3.2.49 When a helicopter stand is used for turning, the minimum dimension of the stand and protection area shall be not less than 2 D.
- 3.2.50 When a helicopter stand is used for turning, it shall be surrounded by a protection area which extends for a distance of 0.4 D from the edge of the helicopter stand.
- 3.2.51 For simultaneous operations, the protection area of helicopter stands and their associated taxi-routes shall not overlap.
- 3.2.52 When intended to be used for ground taxi operations by wheeled helicopters, the dimensions of a helicopter stand shall take into account the minimum turn radius of the wheeled helicopters the stand is intended to serve.
- 3.2.53 A helicopter stand and associated protection area intended to be used for air taxiing shall provide ground effect.
- 3.2.54 No fixed objects shall be permitted on a helicopter stand and the associated protection area.
- 3.2.55 The central zone of the helicopter stand shall be capable of withstanding the traffic of the helicopters it is intended to serve and have a load-bearing area:
- (a) of diameter not less than 0.83 D of the largest helicopter it is intended to serve; or
 - (b) for a helicopter stand intended to be used for ground taxi-through, the same width as the ground taxiway.
- 3.2.56 The central zone of a helicopter stand intended to be used for ground taxiing only shall be static load-bearing.
- 3.2.57 The central zone of a helicopter stand intended to be used for air taxiing shall be dynamic load-bearing.

3.3 Helidecks

Note: The following specifications are for helidecks located on structures engaged in such activities as mineral exploitation, research or construction. See 3.4 for shipboard heliport provisions.

Final approach and take-off areas and touchdown and lift-off areas

Note: For helidecks that have a 1 D or larger FATO it is presumed that the FATO and the TLOF will always occupy the same space and have the same load bearing characteristics so as to be coincidental.



For helidecks that are less than 1 D, the reduction in size is only applied to the TLOF which is a load bearing area. In this case, the FATO remains at 1 D but the portion extending beyond the TLOF perimeter need not be load bearing for helicopters. The TLOF and the FATO may be assumed to be collocated.

- 3.3.1 The specifications in paragraphs 3.3.14 and 3.3.15 shall be applicable for helidecks completed on or after 01 January 2012.
- 3.3.2 A helideck shall be provided with one FATO and one coincident or collocated TLOF.
- 3.3.3 A FATO may be any shape but shall be of sufficient size to contain an area within which can be accommodated a circle of diameter of not less than 1 D of the largest helicopter the helideck is intended to serve.
- 3.3.4 A TLOF may be any shape but shall be of sufficient size to contain:
- (a) for helicopters with an MTOM of more than 3 175 kg, an area within which can be accommodated a circle of diameter not less than 1 D of the largest helicopter the helideck is intended to serve; and
 - (b) for helicopters with an MTOM of 3 175 kg or less, an area within which can be accommodated a circle of diameter not less than 0.83 D of the largest helicopter the helideck is intended to serve.
- 3.3.5 For helicopters with a MTOM of 3175 kg or less, the TLOF should be of sufficient size to contain an area within which can be accommodated a circle of diameter of not less than 1 D of the largest helicopter the helideck is intended to serve.
- 3.3.6 A helideck shall be arranged to ensure that a sufficient and unobstructed air-gap is provided which encompasses the full dimensions of the FATO.
- 3.3.7 The FATO shall be located so as to avoid, as far as is practicable, the influence of environmental effects, including turbulence, over the FATO, which could have an adverse impact on helicopter operations.
- 3.3.8 The TLOF shall be dynamic load-bearing.
- 3.3.9 The TLOF shall provide ground effect.
- 3.3.10 No fixed object shall be permitted around the edge of the TLOF except for frangible objects, which, because of their function, must be located thereon.
- 3.3.11 For any TLOF 10 m or greater and any TLOF designed for use by helicopters having a D-value of greater than 16.0 m, objects installed in the obstacle-free sector whose function requires them to be located on the edge of the TLOF shall not exceed a height of 25 cm.
- 3.3.12 For any TLOF 10 m or greater and any TLOF designed for use by helicopters having a D-value of greater than 16.0 m, objects installed in the obstacle-free sector whose function requires them to be located on the edge of the TLOF, shall not exceed a height of 15 cm.
- 3.3.13 For any TLOF designed for use by helicopters having a D value of 16 m or less, and any TLOF having dimensions of less than 1 D, objects installed in the obstacle-free sector whose function requires them to be located on the edge of the TLOF shall not exceed a height of 5 cm.



3.3.14 Objects whose function requires them to be located within the TLOF (such as lighting or nets) shall not exceed a height of 2.5 cm. Such objects shall only be present if they do not represent a hazard to helicopters.

Note: Examples of potential hazards include nets or raised fittings on the deck that might induce dynamic rollover for helicopters equipped with skids.

3.3.15 Safety devices such as safety nets or safety shelves shall be located around the edge of a helideck but shall not exceed the height of the TLOF.

3.3.16 The surface of the TLOF shall be skid-resistant to both helicopters and persons and be sloped to prevent pooling of water.

3.4 Shipboard heliports

3.4.1 The specifications in paragraph 3.4.16 and 3.4.17 shall be applicable to shipboard heliports completed on or after 1 January 2012 and 1 January 2015, respectively.

3.4.2 When helicopter operating areas are provided in the bow or stern of a ship or are purpose-built above the ship's structure, they shall be regarded as purpose-built shipboard heliports.

Final approach and take-off areas and touchdown and lift-off areas

3.4.3 A shipboard heliport shall be provided with one FATO and one coincidental or collocated TLOF.

3.4.4 A FATO shall be circular, square or octagonal and of sufficient size to contain an area within which can be accommodated a circle of diameter of not less than 1 D of the largest helicopter the heliport is intended to serve.

3.4.5 The TLOF of a shipboard heliport shall be dynamic load-bearing.

3.4.6 The TLOF of a shipboard heliport shall provide ground effect.

3.4.7 For purpose-built shipboard heliports provided in a location other than the bow or stern, the TLOF shall be of sufficient size to contain a circle with a diameter not less than 1 D of the largest helicopter the heliport is intended to serve.

3.4.8 For purpose-built shipboard heliports provided in the bow or stern of a ship, the TLOF shall be of sufficient size to:

- (a) contain a circle with a diameter not less than 1 D of the largest helicopter the heliport is intended to serve; or
- (b) for operations with limited touchdown directions, contain an area within which can be accommodated two opposing arcs of a circle with a diameter of not less than 1 D in the helicopter's longitudinal direction. The minimum width of the heliport shall be not less than 0.83 D. (See Figure 3-7.)
- (c) The ship should be manoeuvred to ensure that the relative wind is appropriate to the direction of the helicopter touchdown heading.



- (d) The touchdown heading of the helicopter should be limited to the angular distance subtended by the 1 D arc headings, minus the angular distance which corresponds to 15 degrees at each end of the arc.
- 3.4.9 For non-purpose-built shipboard heliports, the TLOF shall be of sufficient size to contain a circle with a diameter not less than 1 D of the largest helicopter the heliport is intended to serve.
- 3.4.10 A shipboard heliport shall be arranged to ensure that a sufficient and unobstructed air-gap is provided which encompasses the full dimensions of the FATO.
- 3.4.11 The FATO shall be located to avoid the influence of environmental effects, including turbulence, over the FATO, which could have an adverse impact on helicopter operations.
- 3.4.12 No fixed object shall be permitted around the edge of the TLOF except for frangible objects, which, because of their function, must be located thereon.
- 3.4.13 For any TLOF 1D or greater and any TLOF designed for use by helicopters having a D-value of greater than 16.0 m, objects installed in the obstacle-free sector whose function requires them to be located on the edge of the TLOF shall not exceed a height of 25 cm.
- 3.4.14 For any TLOF 1D or greater and any TLOF designed for use by helicopters having a D-value of greater than 16.0 m, objects installed in the obstacle-free sector whose function requires them to be located on the edge of the TLOF shall not exceed a height of 15 cm.
- 3.4.15 For any TLOF designed for use by helicopters having a D-value of 16.0 m or less, and any TLOF having dimensions of less than 1D, objects in the obstacle-free sector, whose function requires them to be located on the edge of the TLOF, shall not exceed a height of 5 cm.
- 3.4.16 Objects whose function requires them to be located within the TLOF (such as lighting or nets) shall not exceed a height of 2.5 cm. Such objects shall only be present if they do not represent a hazard to helicopters.

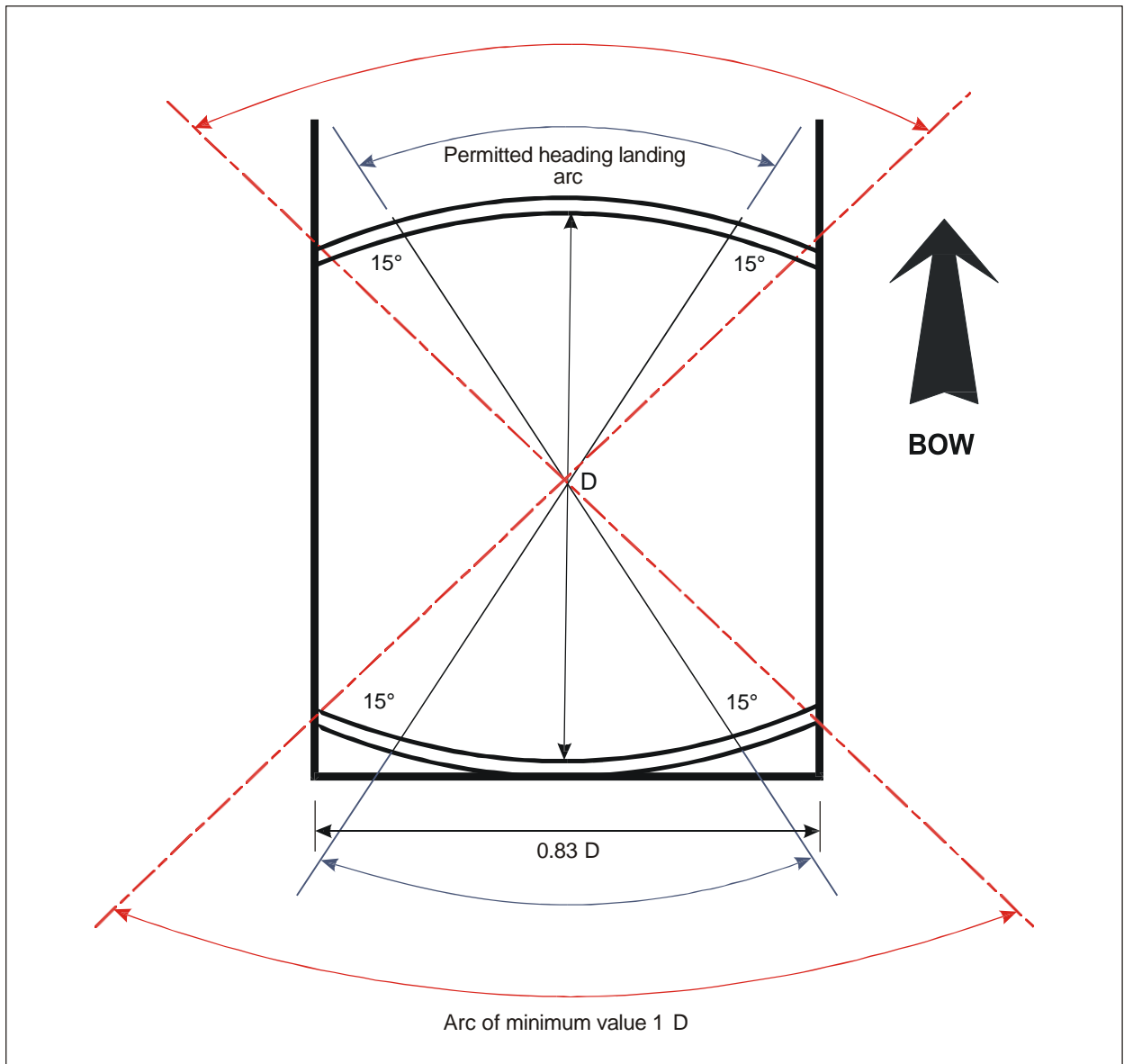

Figure 3-7. Shipboard permitted landing headings for limited heading operations

3.4.17 Safety devices such as safety nets or safety shelves shall be located around the edge of a shipboard heliport, except where structural protection exists, but shall not exceed the height of the TLOF.

3.4.18 The surface of the TLOF shall be skid-resistant to both helicopters and persons.



This Page Intentionally Left Blank



CHAPTER 4

OBSTACLE ENVIRONMENT

4.1 Obstacle limitation surfaces and sectors

Approach surface

- 4.1.1 *Description.* An inclined plane or a combination of planes or, when a turn is involved, a complex surface sloping upwards from the end of the safety area and centred on a line passing through the centre of the FATO.
- 4.1.2 *Characteristics.* The limits of an approach surface shall comprise:
- an inner edge horizontal and equal in length to the minimum specified width/diameter of the FATO plus the safety area, perpendicular to the centre line of the approach surface and located at the outer edge of the safety area;
 - two side edges originating at the ends of the inner edge diverging uniformly at a specified rate from the vertical plane containing the centre line of the FATO; and
 - an outer edge horizontal and perpendicular to the centre line of the approach surface and at a specified height of 152 m (500 ft) above the elevation of the FATO.
- 4.1.3 The elevation of the inner edge shall be the elevation of the FATO at the point on the inner edge that is intersected by the centre line of the approach surface. For heliports intended to be used by helicopters operated in performance class 1 and when approved by an appropriate authority, the origin of the inclined plane may be raised directly above the FATO.
- 4.1.4 The slope(s) of the approach surface shall be measured in the vertical plane containing the centre line of the surface.
- 4.1.5 In the case of an approach surface involving a turn, the surface shall be a complex surface containing the horizontal normal to its centre line and the slope of the centre line shall be the same as that for a straight approach surface.
- 4.1.6 In the case of an approach surface involving a turn, the surface shall not contain more than one curved portion.
- 4.1.7 Where a curved portion of an approach surface is provided, the sum of the radius of arc defining the centre line of the approach surface and the length of the straight portion originating at the inner edge shall not be less than 575 m.

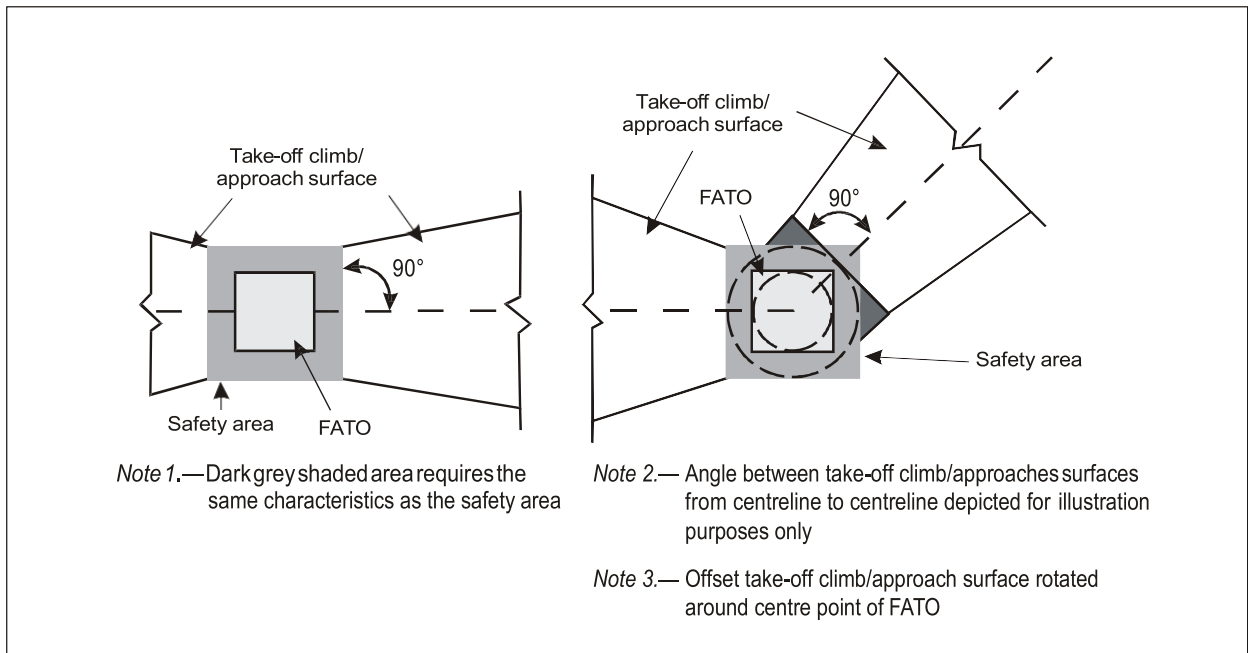

Figure 4-1. Obstacle limitation surfaces — Take-off climb and approach surface

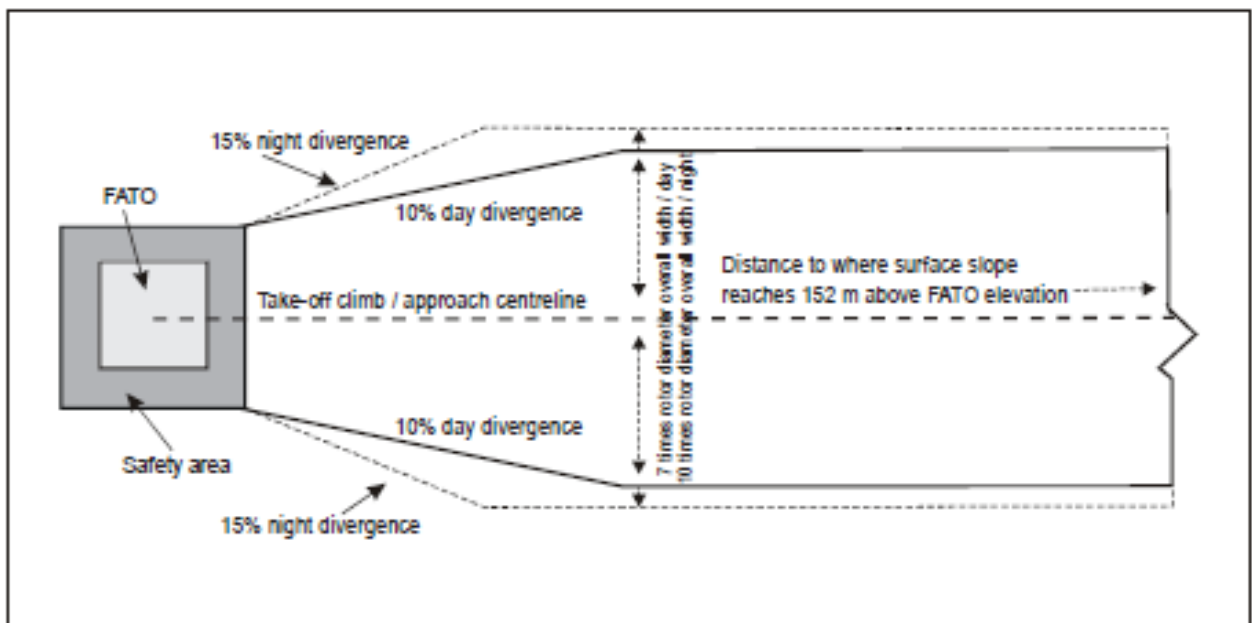

Figure 4-2. Take-off climb/Approach surface width

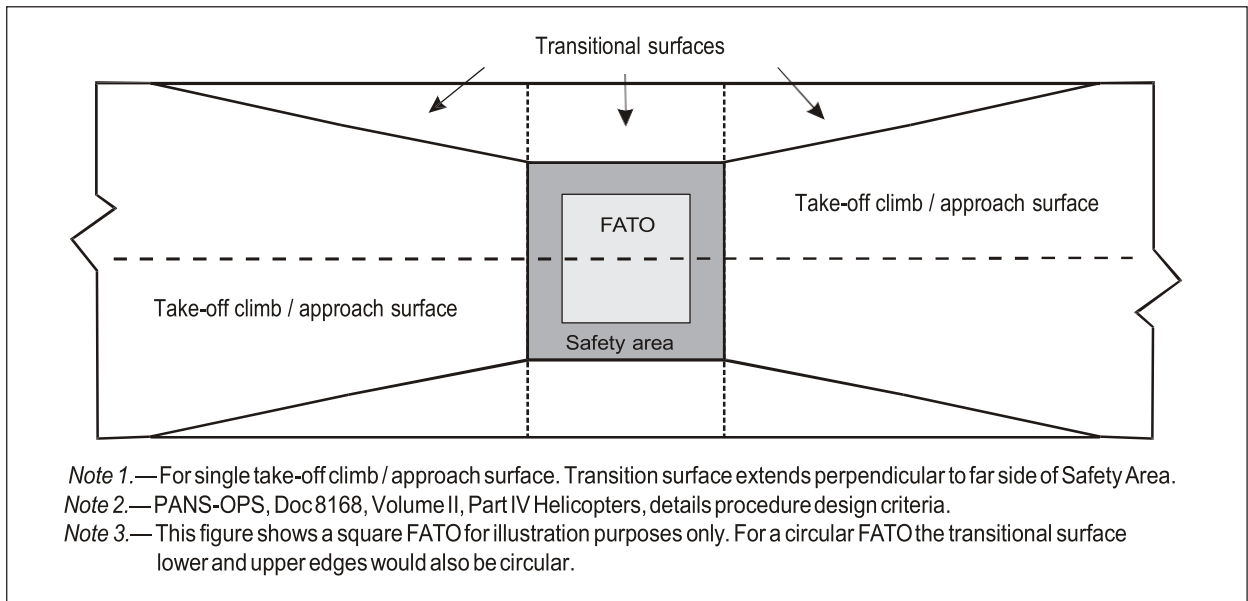

Figure 4-3. Transitional surface for a FATO with a PinS approach procedure with a VSS

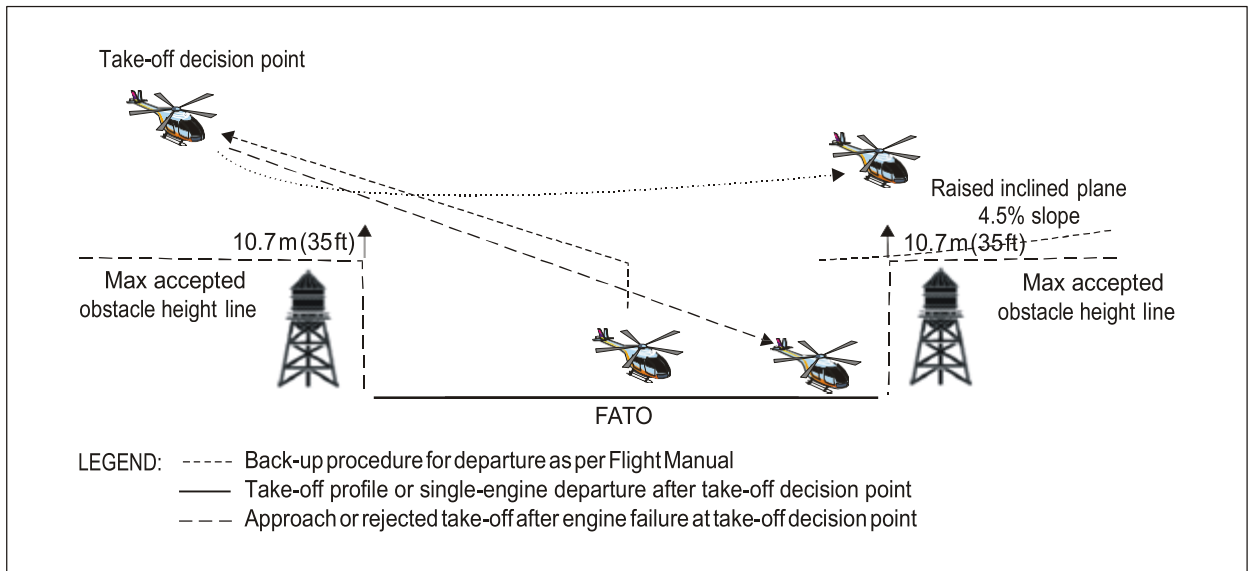

Figure 4-4. Example of raised inclined plane during operations in Performance Class 1

Note 1.— This example diagram does not represent any specific profile, technique or helicopter type and is intended to show a generic example. An approach profile and a back-up procedure for departure profile are depicted. Specific manufacturers operations in performance class 1 may be represented differently in the specific Helicopter Flight Manual. CAR OPS 3 Section 2 provides back-up procedures that may be useful for operations in performance class 1.

Note 2.— The approach/landing profile may not be the reverse of the take-off profile.

Note 3.— Additional obstacle assessment might be required in the area that a back-up procedure is intended. Helicopter performance and the Helicopter Flight Manual limitations will determine the extent of the assessment required.

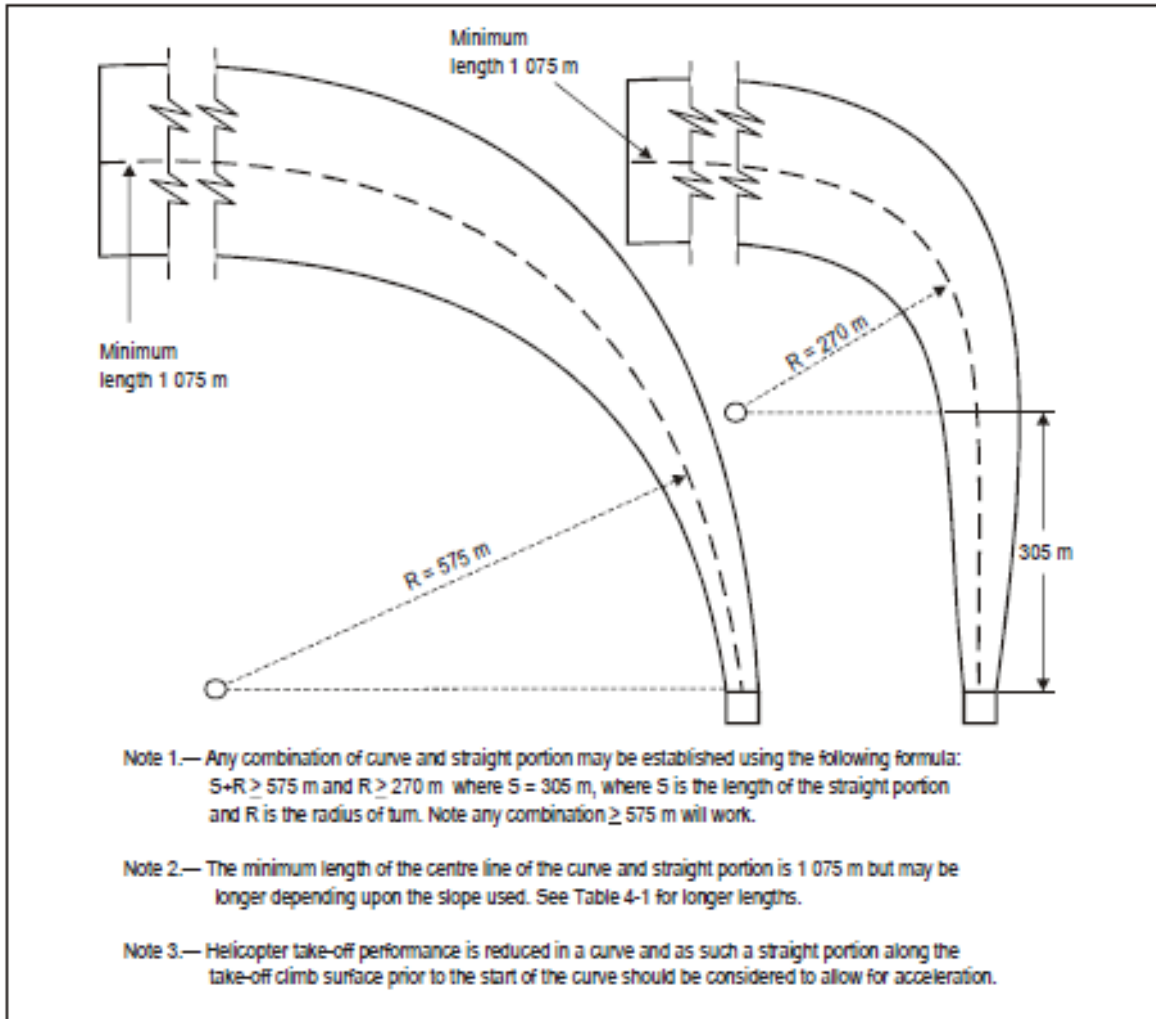

Figure 4-5. Curved approach and take-off climb surface for all FATOs

Table 4-1. Dimensions and slopes of obstacle limitation surfaces for all visual FATOs

SURFACE and DIMENSIONS	SLOPE DESIGN CATEGORIES		
	A	B	C
APPROACH and TAKE-OFF CLIMB SURFACE:			
Length of inner edge	Width of safety area	Width of safety area	Width of safety area
Location of inner edge	Safety area boundary (Clearway boundary if provided)	Safety area boundary	Safety area boundary
Divergence: (1st and 2nd section)			
Day use only	10%	10%	10%
Night use	15%	15%	15%
First Section:			
Length	3 386 m	245 m	1 220 m
Slope	4.5% (1:22.2)	8% (1:12.5)	12.5% (1:8)
Outer Width	(b)	N/A	(b)
Second Section:			
Length	N/A	830 m	N/A

Slope	N/A	16% (1:6.25)	N/A
Outer Width	N/A	(b)	N/A
Total Length from inner edge (a)	3 386 m	1 075 m	1 220 m
Transitional Surface: (FATOs with a PinS approach procedure with a VSS)			
Slope	50% (1:2)	50% (1:2)	50% (1:2)
Height	45 m	45 m	45 m

- (a) The approach and take-off climb surface lengths of 3 386 m, 1 075 m and 1 220 m associated with the respective slopes, brings the helicopter to 152 m (500 ft) above FATO elevation.
- (b) Seven rotor diameters overall width for day operations or 10 rotor diameters overall width for night operations.

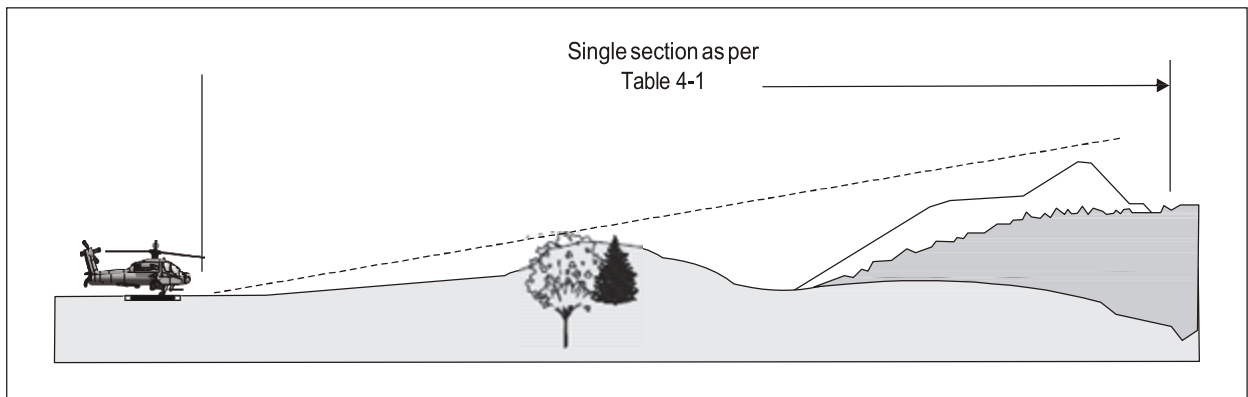

a) Approach and take-off climb surfaces - "A" slope profile - 4.5% design

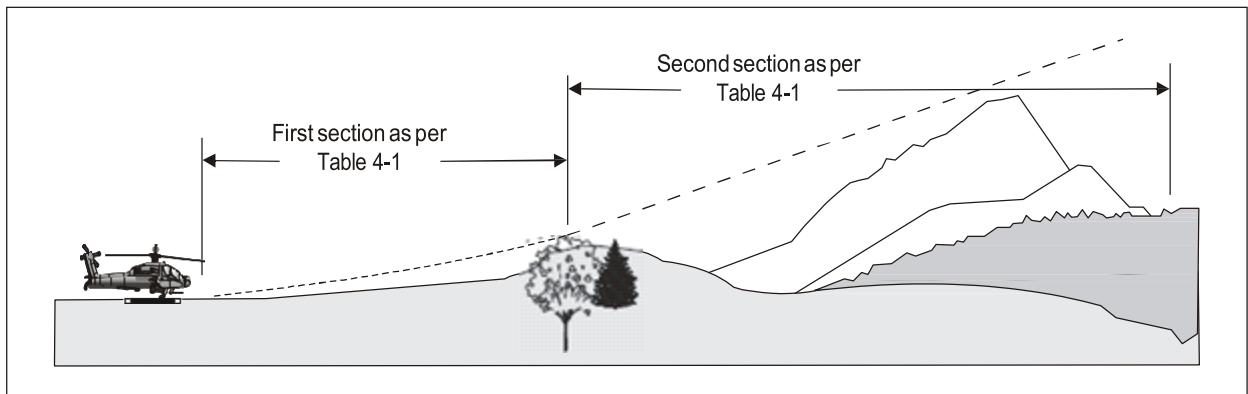

b) Approach and take-off climb surfaces - "B" slope profile - 8% and 16% design

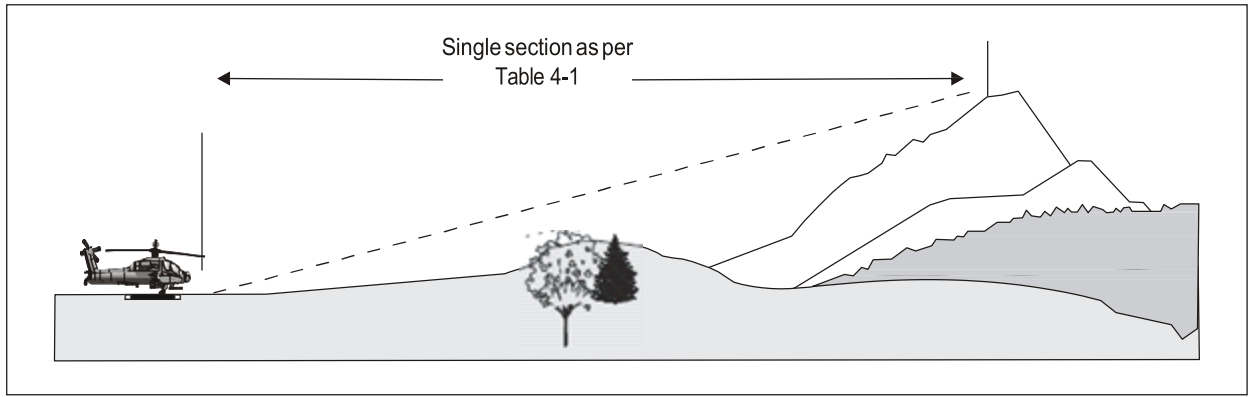

c) Approach and take-off climb surfaces - “C” slope profile - 12.5% design

Figure 4-6. Approach and take-off climb surfaces with different slope design categories

4.1.8 Any variation in the direction of the centre line of an approach surface shall be designed so as not to necessitate a turn radius less than 270 m.

Transitional surface

4.1.9 *Description.* A complex surface along the side of the safety area and part of the side of the approach/take-off climb surface, that slopes upwards and outwards to a predetermined height of 45 m (150ft).

4.1.10 *Characteristics.* The limits of a transitional surface shall comprise:

- a) a lower edge beginning at a point on the side of the approach/take-off climb surface at a specified height above the lower edge extending down the side of the approach/take-off climb surface to the inner edge of the approach/take-off climb surface and from there along the length of the side of the safety area parallel to the centre line of the FATO; and
- b) an upper edge located at a specified height above the lower edge as set out in Table 4-1.

4.1.11 The elevation of a point on the lower edge shall be:

- (a) along the side of the approach/take-off climb surface — equal to the elevation of the approach/take-off climb surface at that point; and
- (b) along the safety area — equal to the elevation of the inner edge of the approach/take-off climb surface.

4.1.12 The slope of the transitional surface shall be measured in a vertical plane at right angles to the centre line of the FATO.

Take-off climb surface

4.1.13 *Description.* An inclined plane, a combination of planes or, when a turn is involved, a complex surface sloping upwards from the end of the safety area and centred on a line passing through the centre of the FATO.

4.1.14 *Characteristics.* The limits of a take-off climb surface shall comprise:



- (a) an inner edge horizontal and equal in length to the minimum specified width/diameter of the FATO plus the safety area, perpendicular to the centre line of the take-off climb surface and located at the outer edge of the safety area;
- (b) two side edges originating at the ends of the inner edge and diverging uniformly at a specified rate from the vertical plane containing the centre line of the FATO; and
- (c) an outer edge horizontal and perpendicular to the centre line of the take-off climb surface and at a specified height of 152 m (500 ft) above the elevation of the FATO.

4.1.15 The elevation of the inner edge shall be the elevation of the FATO at the point on the inner edge that is intersected by the centre line of the take-off climb surface. For heliports intended to be used by helicopters operated in performance class 1 and when approved by an appropriate authority, the origin of the inclined plane may be raised directly above the FATO.

4.1.16 Where a clearway is provided the elevation of the inner edge of the take-off climb surface shall be located at the outer edge of the clearway at the highest point on the ground based on the centre line of the clearway.

4.1.17 In the case of a straight take-off climb surface, the slope shall be measured in the vertical plane containing the centre line of the surface.

4.1.18 In the case of a take-off climb surface involving a turn, the surface shall be a complex surface containing the horizontal normal to its centre line and the slope of the centre line shall be the same as that for a straight take-off climb surface.

4.1.19 In the case of a take-off climb surface involving a turn, the surface shall not contain more than one curved portion.

4.1.20 Where a curved portion of a take-off climb surface is provided the sum of the radius of arc defining the centre line of the take-off climb surface and the length of the straight portion originating at the inner edge shall not be less than 575 m.

4.1.21 Any variation in the direction of the centre line of a take-off climb surface shall be designed so as not to necessitate a turn of radius less than 270 m.

Obstacle-free sector/surface — helidecks

4.1.22 *Description.* A complex surface originating at and extending from, a reference point on the edge of the FATO of a helideck. In the case of a TLOF of less than 1 D, the reference point shall be located not less than 0.5 D from the centre of the TLOF.

4.1.23 *Characteristics.* An obstacle-free sector/surface shall subtend an arc of specified angle.

4.1.24 A helideck obstacle-free sector shall comprise of two components, one above and one below helideck level:

- (a) *Above helideck level.* The surface shall be a horizontal plane level with the elevation of the helideck surface that subtends an arc of at least 210 degrees with the apex located on the periphery of the D circle extending outwards to a distance that will allow for an unobstructed departure path appropriate to the helicopter the helideck is intended to serve.



- (b) *Below helideck level.* Within the (minimum) 210-degree arc, the surface shall additionally extend downward from the edge of the FATO below the elevation of the helideck to water level for an arc of not less than 180 degrees that passes through the centre of the FATO and outwards to a distance that will allow for safe clearance from the obstacles below the helideck in the event of an engine failure for the type of helicopter the helideck is intended to serve.

Limited obstacle sector/surface — helidecks

4.1.25 *Description.* A complex surface originating at the reference point for the obstacle-free sector and extending over the arc not covered by the obstacle-free sector within which the height of obstacles above the level of the TLOF will be prescribed.

4.1.26 *Characteristics.* A limited obstacle sector shall not subtend an arc greater than 150 degrees. Its dimensions and location shall be as indicated in Figure 4-8 for a 1 D FATO with coincidental TLOF and Figure 4-9 for a 0.83 D TLOF.

4.2 Obstacle limitation requirements

Surface-level heliports

4.2.1 The following obstacle limitation surfaces shall be established for a FATO at heliports with a PinS approach procedure utilizing a visual segment surface:

- (a) take-off climb surface;
- (b) approach surface; and
- (c) transitional surfaces.

4.2.2 The following obstacle limitation surfaces shall be established for a FATO at heliports, other than specified in 4.2.1, including heliports with a PinS approach procedure where a visual segment surface is not provided:

- (a) take-off climb surface; and
- (b) approach surface.

4.2.3 The slopes of the obstacle limitation surfaces shall not be greater than, and their other dimensions not less than, those specified in Table 4-1 and shall be located as shown in Figures 4-1, 4-2 and 4-6.

4.2.4 For heliports that have an approach/take-off climb surface with a 4.5 per cent slope design, objects shall be permitted to penetrate the obstacle limitation surface, if the results of an aeronautical study approved by an appropriate authority have reviewed the associated risks and mitigation measures.

4.2.5 New objects or extensions of existing objects shall not be permitted above any of the surfaces in 4.2.1 and 4.2.2 except when shielded by an existing immovable object or after an aeronautical study approved by an appropriate authority determines that the object will not adversely affect the safety or significantly affect the regularity of operations of helicopters.

4.2.6 Existing objects above any of the surfaces in 4.2.1 and 4.2.2 shall be removed except when the object is shielded by an existing immovable object or after an aeronautical study approved by an appropriate authority determines that the object does not adversely affect the safety or significantly affect the regularity of operations of helicopters.

4.2.7 A surface-level heliport shall have at least one approach and take-off climb surface. An aeronautical study shall be undertaken by an appropriate authority when only a single approach and take-off climb surface is provided considering as a minimum, the following factors:

- (a) the area/terrain over which the flight is being conducted;
- (b) the obstacle environment surrounding the heliport;
- (c) the performance and operating limitations of helicopters intending to use the heliport; and
- (d) the local meteorological conditions including the prevailing winds.

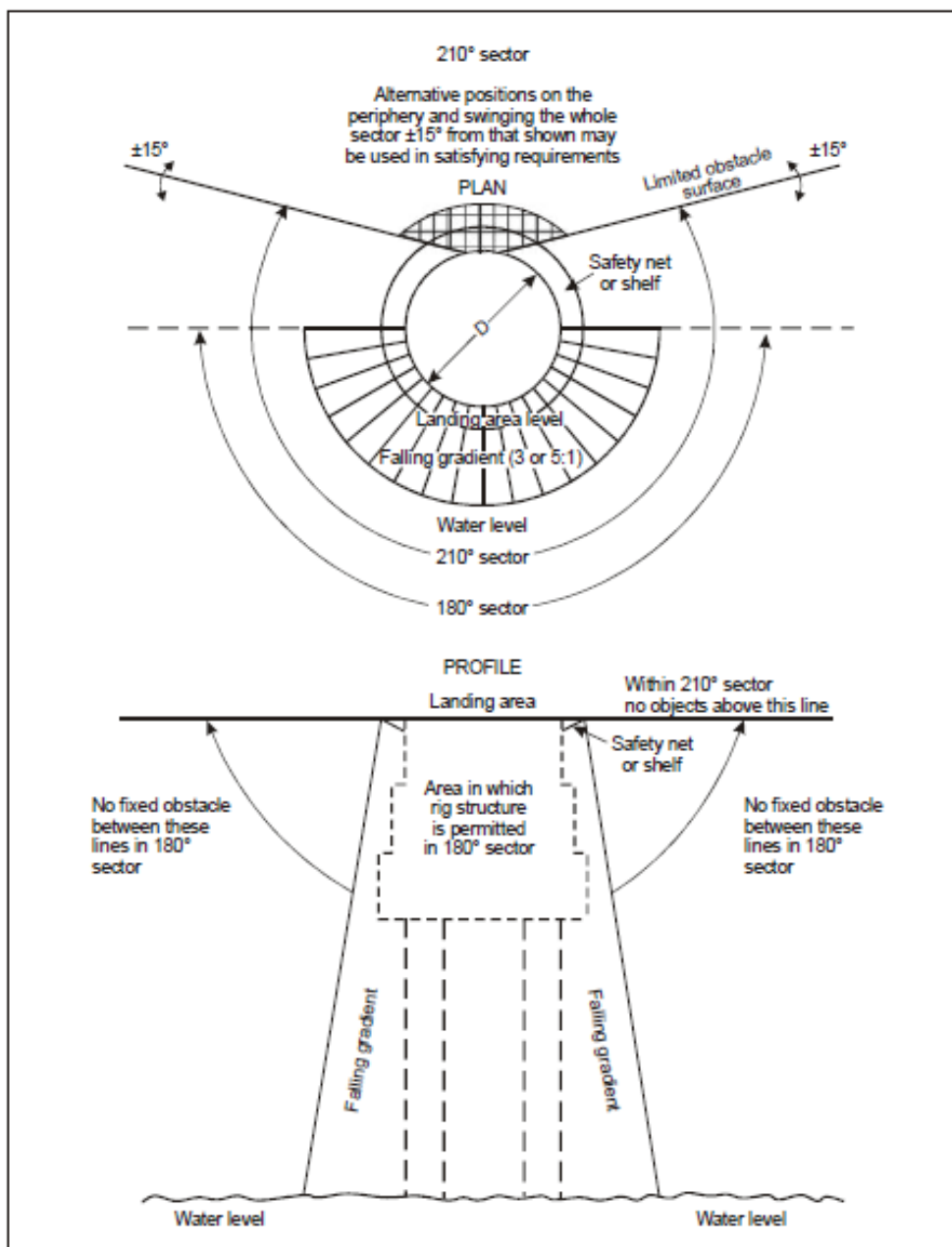

Figure 4.7. Helideck obstacle-free sector

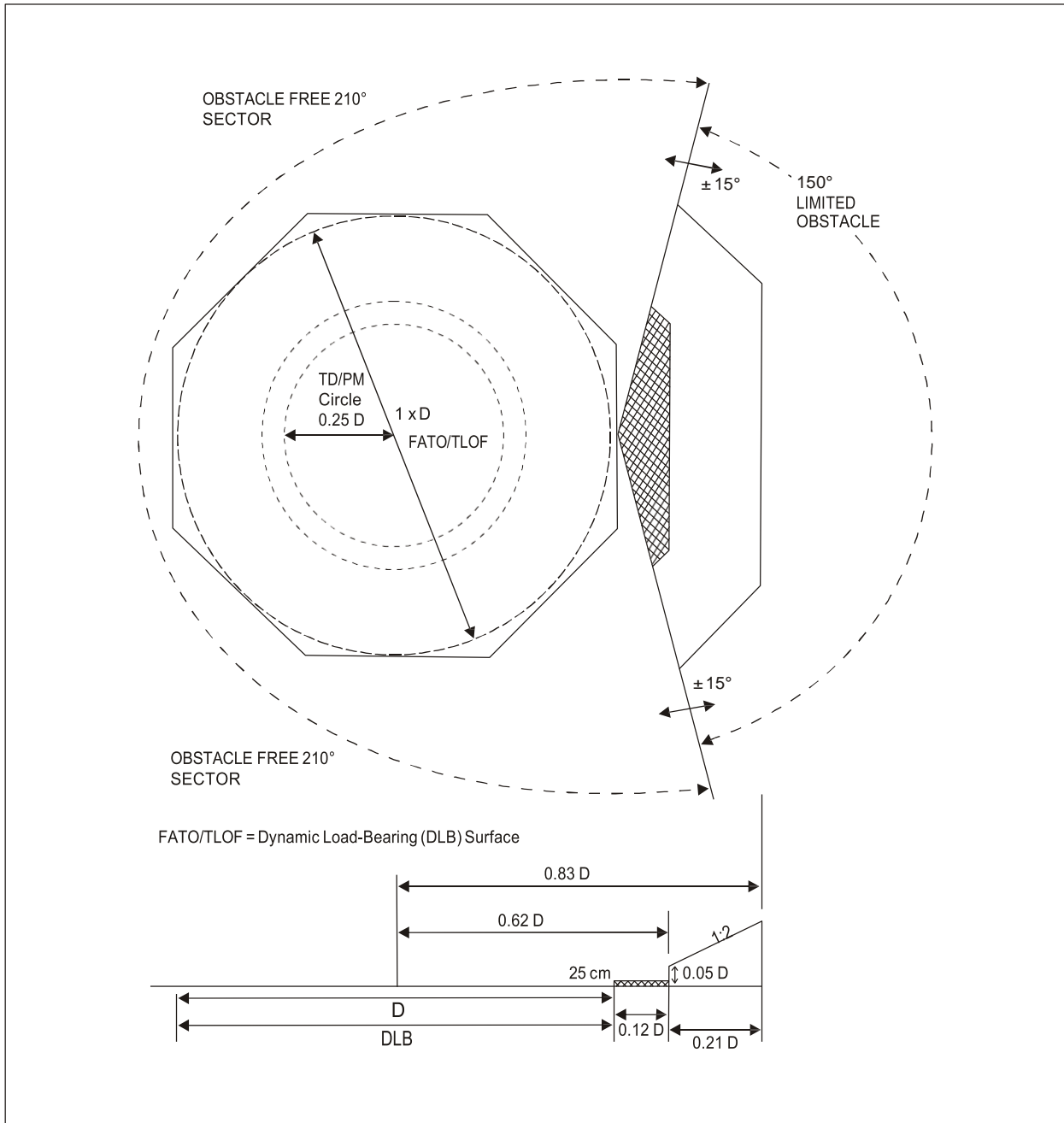

Figure 4-8. Helideck obstacle limitation sectors and surfaces for a FATO and coincidental TLOF of 1 D and larger

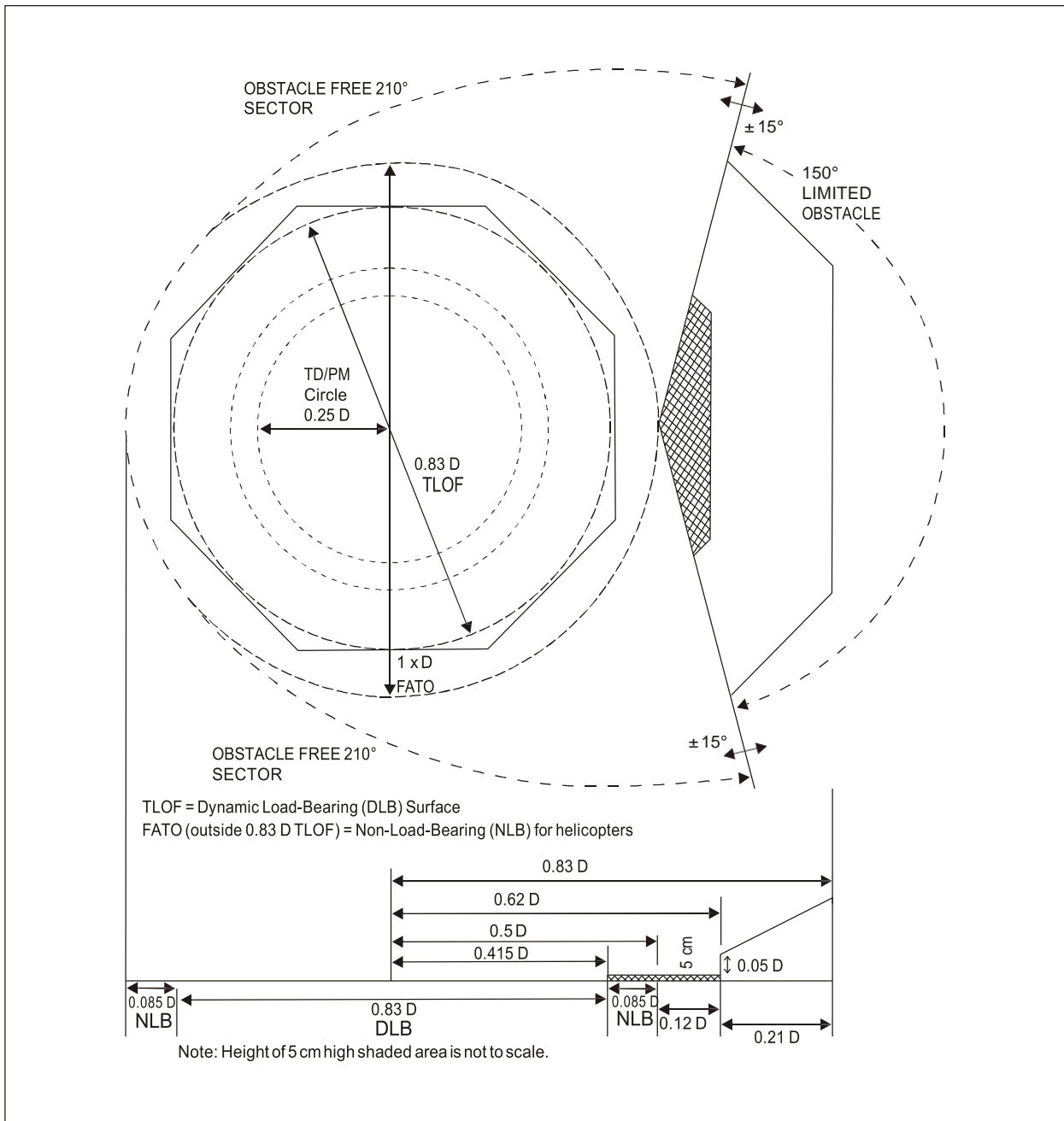

Figure 4-9. Helideck obstacle limitation sectors and surfaces for a TLOF of 0.83 D and larger

4.2.8 A surface-level heliport shall have at least two approach and take-off climb surfaces to avoid downwind conditions, minimize crosswind conditions and permit for a balked landing.

Elevated heliports

4.2.9 The obstacle limitation surfaces for elevated heliports shall conform to the requirements for surface-level heliports specified in 4.2.1 to 4.2.6.

4.2.10 An elevated heliport shall have at least one approach and take-off climb surface. An aeronautical study shall be undertaken by an appropriate authority when only a single approach and take-off climb surface is provided considering as a minimum, the following factors:

- (a) the area/terrain over which the flight is being conducted;
- (b) the obstacle environment surrounding the heliport;



- (c) the performance and operating limitations of helicopters intending to use the heliport; and
- (d) the local meteorological conditions including the prevailing winds.

4.2.11 An elevated heliport shall have at least two approach and take-off climb surfaces to avoid downwind conditions, minimize crosswind conditions and permit for a balked landing.

Helidecks

4.2.12 A helideck shall have an obstacle-free sector.

4.2.13 There shall be no fixed obstacles within the obstacle-free sector above the obstacle-free surface.

4.2.14 In the immediate vicinity of the helideck, obstacle protection for helicopters shall be provided below the helideck level. This protection shall extend over an arc of at least 180 degrees with the origin at the centre of the FATO, with a descending gradient having a ratio of one unit horizontally to five units vertically from the edges of the FATO within the 180-degree sector. This descending gradient may be reduced to a ratio of one unit horizontally to three units vertically within the 180-degree sector for multi-engine helicopters operated in performance class 1 or 2. (See Figure 4-7.)

4.2.15 For a TLOF of 1 D and larger, within the 150-degree limited obstacle surface/sector out to a distance of 0.12 D measured from the point of origin of the limited obstacle sector, objects shall not exceed a height of 25 cm above the TLOF. Beyond that arc, out to an overall distance of a further 0.21 D measured from the end of the first sector, the limited obstacle surface rises at a rate of one unit vertically for each two units horizontally originating at a height 0.05 D above the level of the TLOF. (See Figure 4-8.)

4.2.16 For a TLOF less than 1 D within the 150-degree limited obstacle surface/sector out to a distance of 0.62 D and commencing from a distance 0.5 D, both measured from the centre of the TLOF, objects shall not exceed a height of 5 cm above the TLOF. Beyond that arc, out to an overall distance of 0.83 D from the centre of the TLOF, the limited obstacle surface rises at a rate of one unit vertically for each two units horizontally originating at a height 0.05 D above the level of the TLOF. (See Figure 4-9.)

Shipboard heliports

4.2.17 The specifications in 4.2.20 and 4.2.22 shall be applicable for shipboard heliports completed on or after 1 January 2012.

Purpose-built heliports located forward or aft

4.2.18 When helicopter operating areas are provided in the bow or stern of a ship they shall apply the obstacle criteria for helidecks.

Amidships location — purpose-built and non-purpose-built

4.2.19 Forward and aft of a TLOF of 1 D and larger shall be two symmetrically located sectors, each covering an arc of 150 degrees, with their apexes on the periphery of the TLOF. Within the area enclosed by these two sectors, there shall be no objects rising above the level of the TLOF, except those aids essential for the safe operation of a helicopter and then only up to a maximum height of 25 cm.

4.2.20 Objects whose function requires them to be located within the TLOF (such as lighting or nets) shall not exceed a height of 2.5 cm. Such objects shall only be present if they do not represent a hazard to helicopters.

4.2.21 To provide further protection from obstacles fore and aft of the TLOF, rising surfaces with gradients of one unit vertically to five units horizontally shall extend from the entire length of the edges of the two 150-degree sectors. These surfaces shall extend for a horizontal distance equal to at least 1 D of the largest helicopter the TLOF is intended to serve and shall not be penetrated by any obstacle. (See Figure 4-10.)

Non-purpose-built heliports Ship’s side location

4.2.22 No objects shall be located within the TLOF except those aids essential for the safe operation of a helicopter (such as nets or lighting) and then only up to a maximum height of 2.5 cm. Such objects shall only be present if they do not represent a hazard to helicopters.

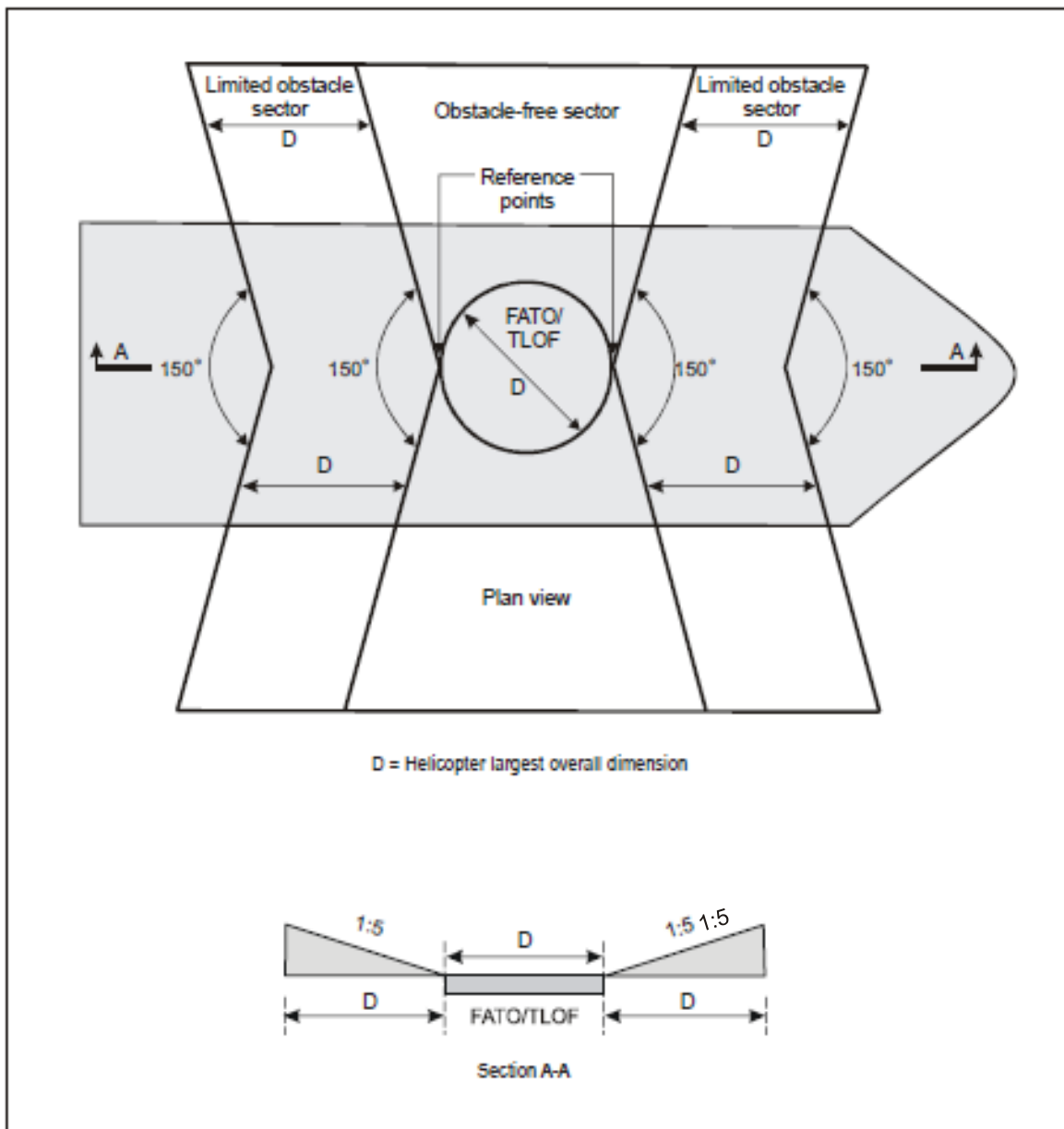

Figure 4-10. Amidship’s location — Shipboard heliport obstacle limitation surfaces



4.2.23 From the fore and aft mid-points of the D circle in two segments outside the circle, limited obstacle areas shall extend to the ship’s rail to a fore and aft distance of 1.5 times the fore-to-aft-dimension of the TLOF, located symmetrically about the athwartships bisector of the D circle. Within these areas there shall be no objects rising above a maximum height of 25 cm above the level of the TLOF. (See Figure 4-11.) Such objects shall only be present if they do not represent a hazard to helicopters.

4.2.24 A limited obstacle sector horizontal surface shall be provided, at least 0.25 D beyond the diameter of the D circle, which shall surround the inboard sides of the TLOF to the fore and aft mid-points of the D circle. The limited obstacle sector shall continue to the ship’s rail to a fore and aft distance of 2.0 times the fore-to-aft dimension of the TLOF, located symmetrically about the athwartships bisector of the D circle. Within this sector there shall be no objects rising above a maximum height of 25 cm above the level of the TLOF.

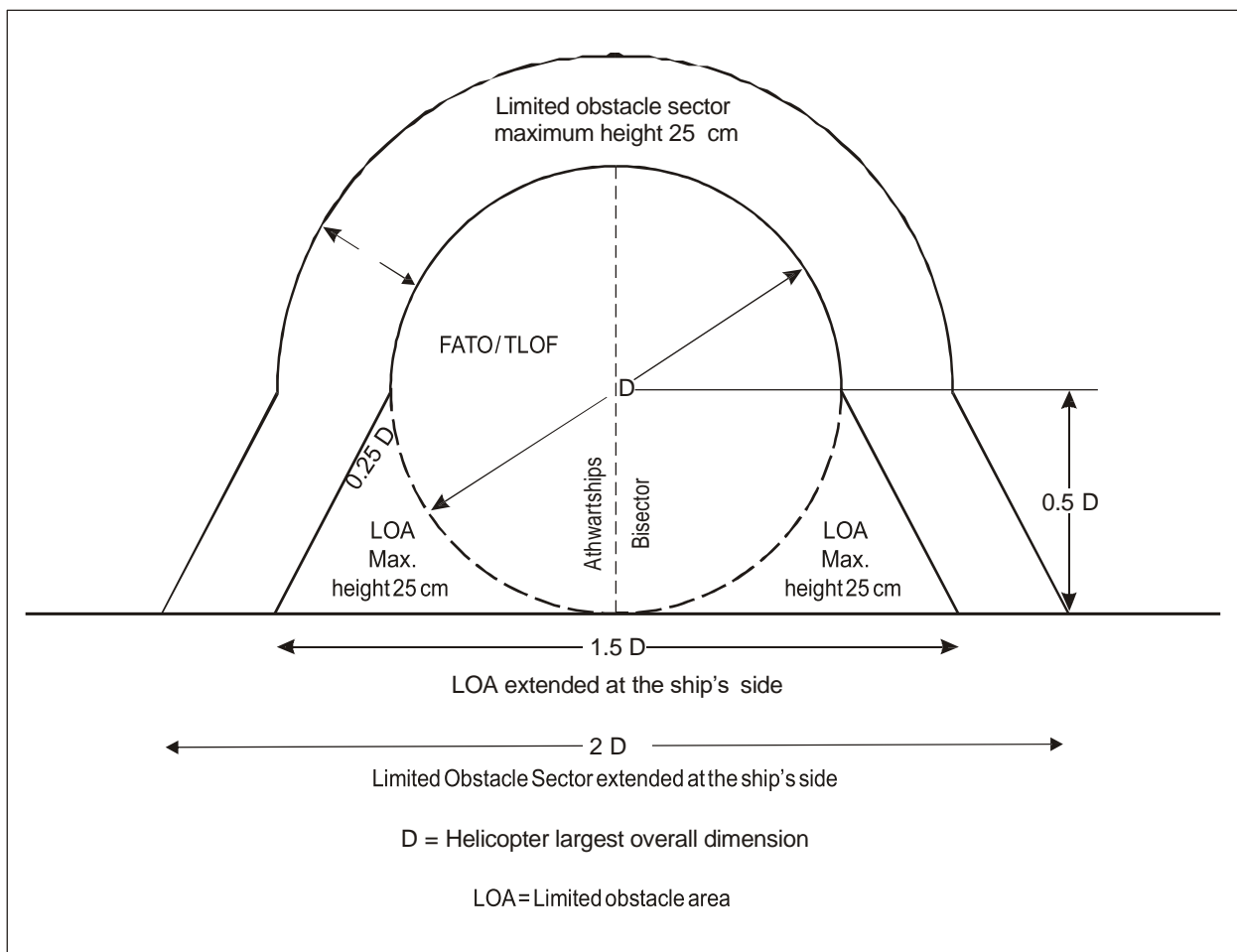

Figure 4-11. Ships-side non-purpose-built heliport obstacle limitation sectors and surfaces

Winching areas

4.2.25 An area designated for winching on-board ships shall be comprised of a circular clear zone of diameter 5 m and extending from the perimeter of the clear zone, a concentric manoeuvring zone of diameter 2 D. (See Figure 4-12.)

4.2.26 The manoeuvring zone shall be comprised of two areas:

- (a) the inner manoeuvring zone extending from the perimeter of the clear zone and of a circle of diameter not less than 1.5 D; and

- (b) the outer manoeuvring zone extending from the perimeter of the inner manoeuvring zone and of a circle of diameter not less than 2 D.

4.2.27 Within the clear zone of a designated winching area, no objects shall be located above the level of its surface.

4.2.28 Objects located within the inner manoeuvring zone of a designated winching area shall not exceed a height of 3 m.

4.2.29 Objects located within the outer manoeuvring zone of a designated winching area shall not exceed a height of 6 m.

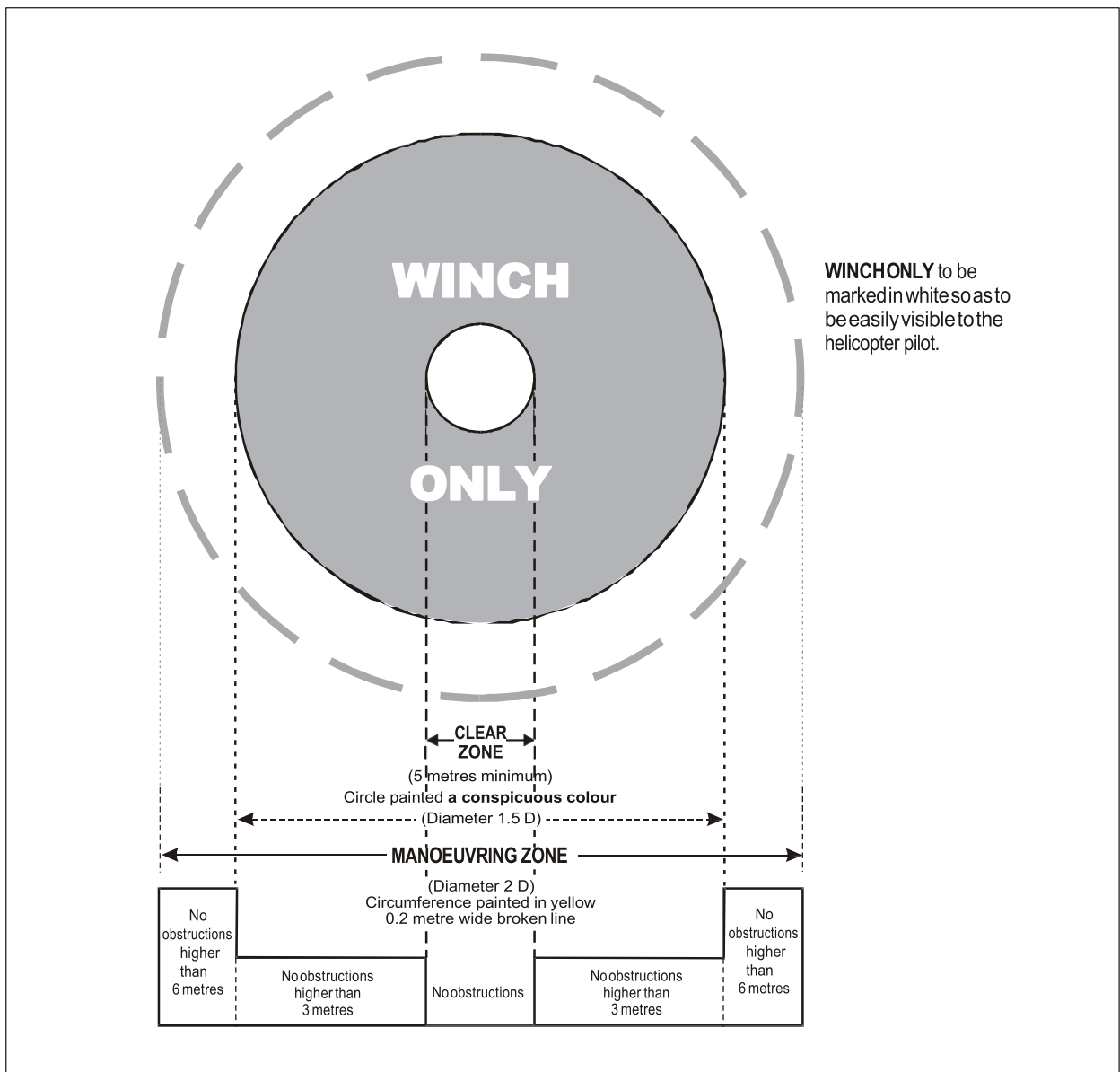

Figure 4-12. Winching area of a ship



This Page Intentionally Left Blank



CHAPTER 5

VISUAL AIDS

5.1 Indicators

5.1.1 Wind direction indicators

Application

5.1.1.1A heliport shall be equipped with at least one wind direction indicator.

Location

5.1.1.2A wind direction indicator shall be located so as to indicate the wind conditions over the FATO and TLOF and in such a way as to be free from the effects of airflow disturbances caused by nearby objects or rotor downwash. It shall be visible from a helicopter in flight, in a hover or on the movement area.

5.1.1.3 Where a TLOF and/or FATO may be subject to a disturbed airflow, then additional wind direction indicators located close to the area should be provided to indicate the surface wind on the area.

Characteristics

5.1.1.4 A wind direction indicator shall be constructed so that it gives a clear indication of the direction of the wind and a general indication of the wind speed.

5.1.1.5 An indicator should be a truncated cone made of lightweight fabric and should have the following minimum dimensions:

	Surface-level heliports	Elevated heliports and helidecks
<i>Length</i>	2.4 m	1.2 m
<i>Diameter (larger end)</i>	0.6 m	0.3 m
<i>Diameter (smaller end)</i>	0.3 m	0.15 m

5.1.1.6 The colour of the wind direction indicator should be so selected as to make it clearly visible and understandable from a height of at least 200 m (650 ft) above the heliport, having regard to background. Where practicable, a single colour, preferably white or orange, should be used. Where a combination of two colours is required to give adequate conspicuity against changing backgrounds, they should preferably be orange and white, red and white, or black and white, and should be arranged in five alternate bands the first and last band being the darker colour.

5.1.1.7 A wind direction indicator at a heliport intended for use at night shall be illuminated.

5.2 Markings and markers

5.2.1 Winching area marking

Application

5.2.1.1 Winching area markings shall be provided at a designated winching area. (See Figure 4-12.)



Location

5.2.1.2 Winching area markings shall be located so that their centre(s) coincides with the centre of the clear zone of the winching area. (See Figure 4-12.)

Characteristics

5.2.1.3 Winching area markings shall comprise a winching area clear zone marking and a winching area manoeuvring zone marking.

5.2.1.4 A winching area clear zone marking shall consist of a solid circle of diameter not less than 5 m and of a conspicuous colour.

5.2.1.5 A winching area manoeuvring zone marking shall consist of a broken circle line of 30 cm in width and of a diameter not less than 2 D and be marked in a conspicuous colour. Within it “WINCH ONLY” shall be marked to be easily visible to the pilot.

5.2.2 Heliport identification marking

Application

5.2.2.1 Heliport identification markings shall be provided at a heliport.

Location — All FATOs except runway-type FATOs

5.2.2.2 A heliport identification marking shall be located at or near the centre of the FATO.

5.2.2.3 On a FATO which contains a TLOF, a heliport identification marking shall be located in the FATO so the position of it coincides with the centre of the TLOF.

Location — Runway-type FATOs

5.2.2.4 A heliport identification marking shall be located in the FATO and when used in conjunction with FATO designation markings, shall be displayed at each end of the FATO as shown in Figure 5-2.

Characteristics

5.2.2.5 A heliport identification marking, except for a heliport at a hospital, shall consist of a letter H, white in colour. The dimensions of the H marking shall be no less than those shown in Figure 5-3 and where the marking is used for a runway-type FATO, its dimensions shall be increased by a factor of 3 as shown in Figure 5-2.

5.2.2.6 A heliport identification marking for a heliport at a hospital shall consist of a letter H, red in colour, on a white cross made of squares adjacent to each of the sides of a square containing the H as shown in Figure 5-3.

5.2.2.7 A heliport identification marking shall be oriented with the cross arm of the H at right angles to the preferred final approach direction. For a helideck the cross arm shall be on or parallel to the bisector of the obstacle-free sector. For a non-purpose-built shipboard heliport located on a ship's side, the cross arm shall be parallel with the side of the ship.

5.2.2.8 On a helideck or a shipboard heliport where the D value is 16.0 m or larger, the size of the heliport identification H marking shall have a height of 4 m with an overall width not exceeding 3 m and a stroke width not exceeding 0.75 m. Where the D value is less than 16.0 m, the size of the heliport identification H marking shall have a height of 3 m with an overall width not exceeding 2.25 m and a stroke width not exceeding 0.5 m.

5.2.3 Maximum allowable mass marking

Application

5.2.3.1 A maximum allowable mass marking shall be displayed at an elevated heliport, a helideck and a shipboard heliport.

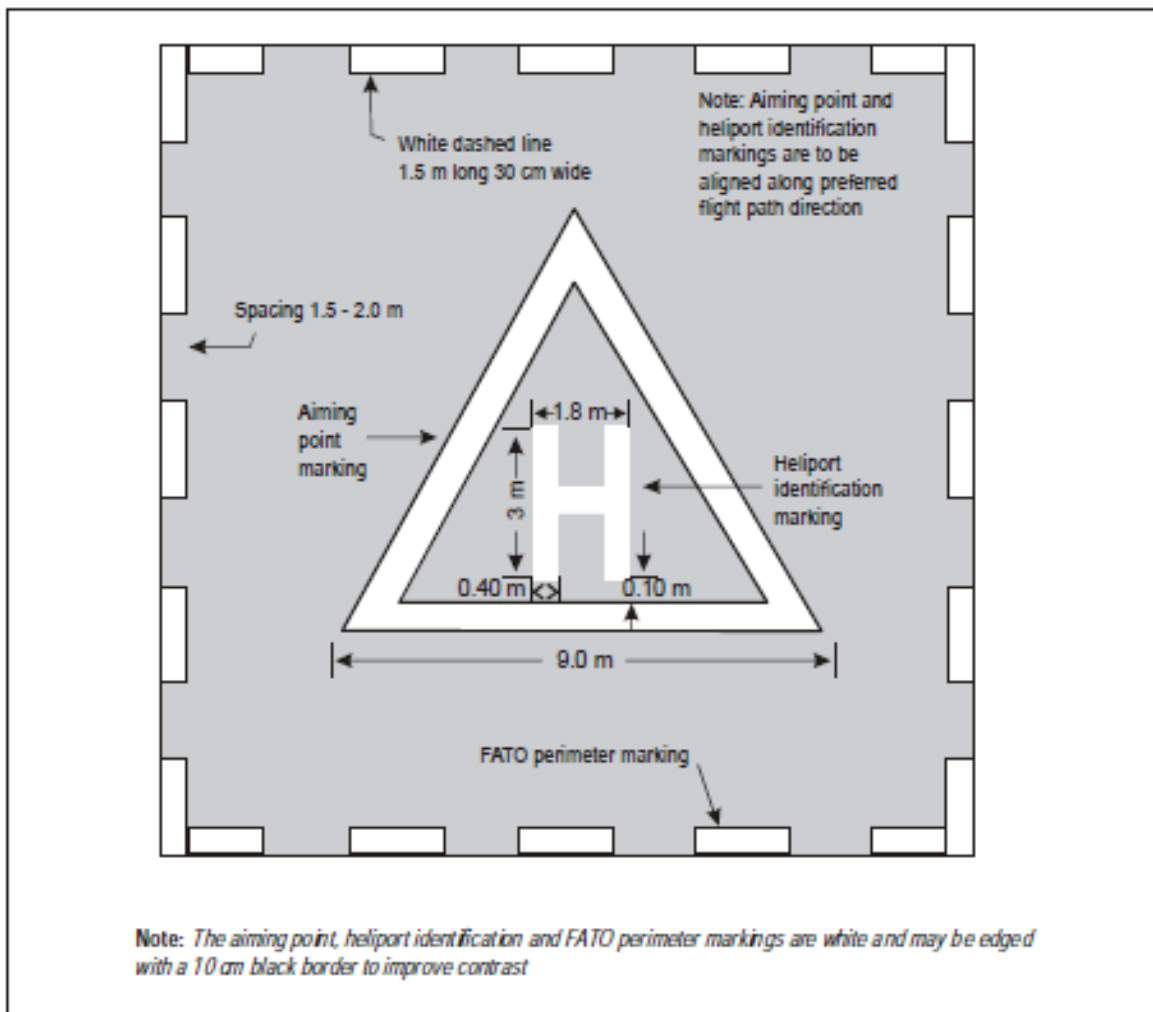

Figure 5-1. Combined heliport identification, aiming point and FATO perimeter marking

5.2.3.2 A maximum allowable mass marking should be displayed at a surface-level heliport.

Location

5.2.3.3 A maximum allowable mass marking should be located within the TLOF or FATO and so arranged as to be readable from the preferred final approach direction.

Characteristics

5.2.3.4 A maximum allowable mass marking shall consist of a one, two or three-digit number.

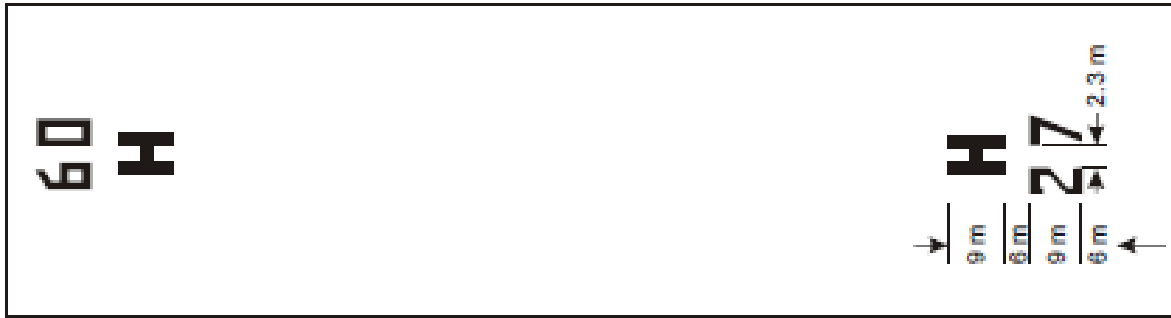

Figure 5-2. FATO designation marking and heliport identification marking for a runway-type FATO

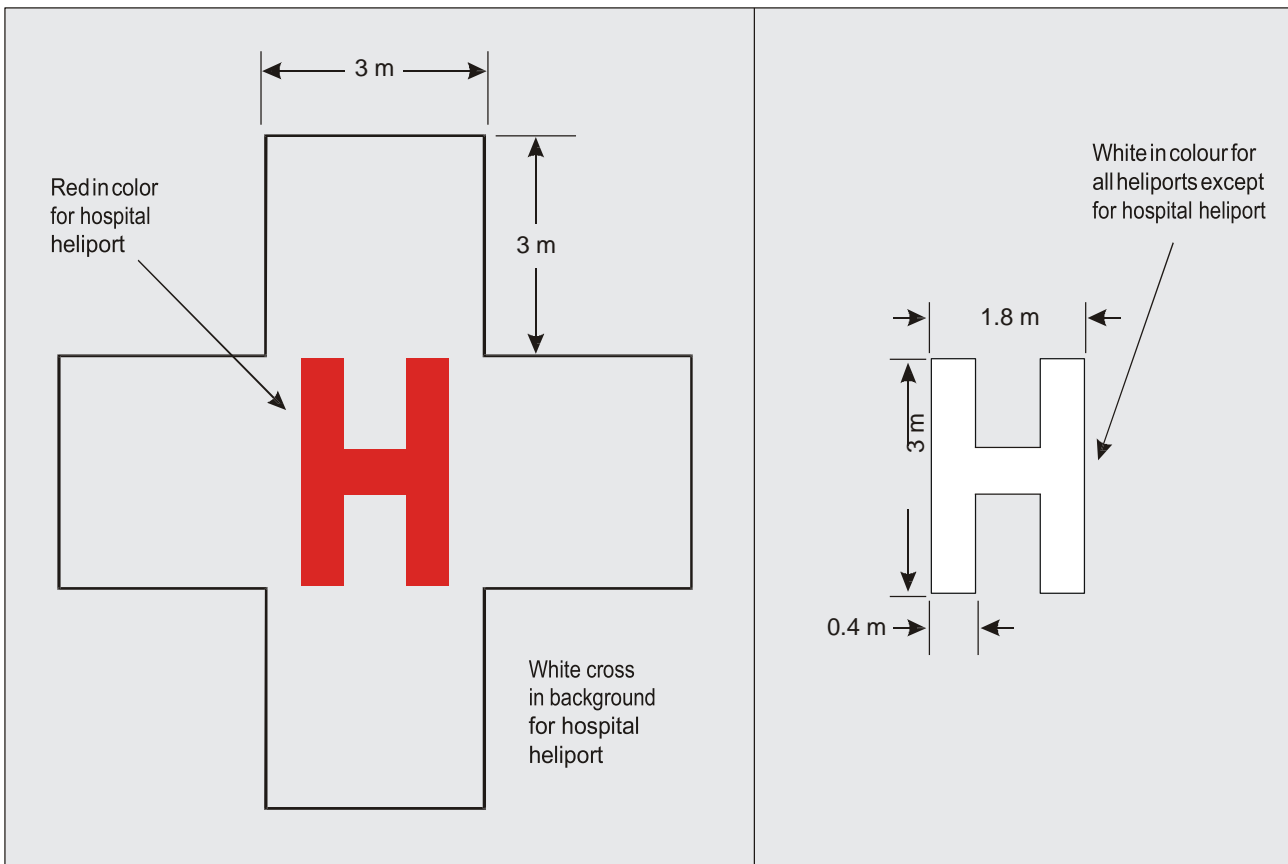

Figure 5-3. Hospital heliport identification and heliport identification marking

5.2.3.5 The maximum allowable mass shall be expressed in tonnes (1 000 kg) rounded down to the nearest 1 000 kg followed by a letter “t”. Where States use mass in pounds, the maximum allowable mass marking shall indicate the allowable helicopter mass in thousands of pounds rounded down to the nearest 1 000 lbs.

5.2.3.6 The maximum allowable mass should be expressed to the nearest 100 kg. The marking should be presented to one decimal place and rounded to the nearest 100 kg followed by the letter “t”. Where States use mass in pounds, the maximum allowable mass marking should indicate the allowable helicopter mass in hundreds of pounds rounded to the nearest 100 lb.

5.2.3.7 When the maximum allowable mass is expressed to 100 kg, the decimal place should be preceded with a decimal point marked with a 30 cm square.

***All FATOs except runway-type FATOs***

5.2.3.8 The numbers and the letter of the marking shall have a colour contrasting with the background and shall be in the form and proportion shown in Figure 5-4 for a FATO with a dimension of more than 30 m. For a FATO with a dimension of between 15 m to 30 m the height of the numbers and the letter of the marking shall be a minimum of 90 cm, and for a FATO with a dimension of less than 15 m the height of the numbers and the letter of the marking shall be a minimum of 60 cm, each with a proportional reduction in width and thickness.

Runway-type FATOs

5.2.3.9 The numbers and the letter of the marking shall have a colour contrasting with the background and should be in the form and proportion shown in Figure 5-4.

5.2.4 D-value marking***Application******All FATOs except runway-type FATOs***

5.2.4.1 The D-value marking shall be displayed at a helideck and at a shipboard heliport.

Runway-type FATOs

5.2.4.2 The D-value marking shall be displayed at surface-level and elevated heliports designed for helicopters operated in Performance Class 2 or 3.

Location

5.2.4.3 A D-value marking shall be located within the TLOF or FATO and so arranged as to be readable from the preferred final approach direction.

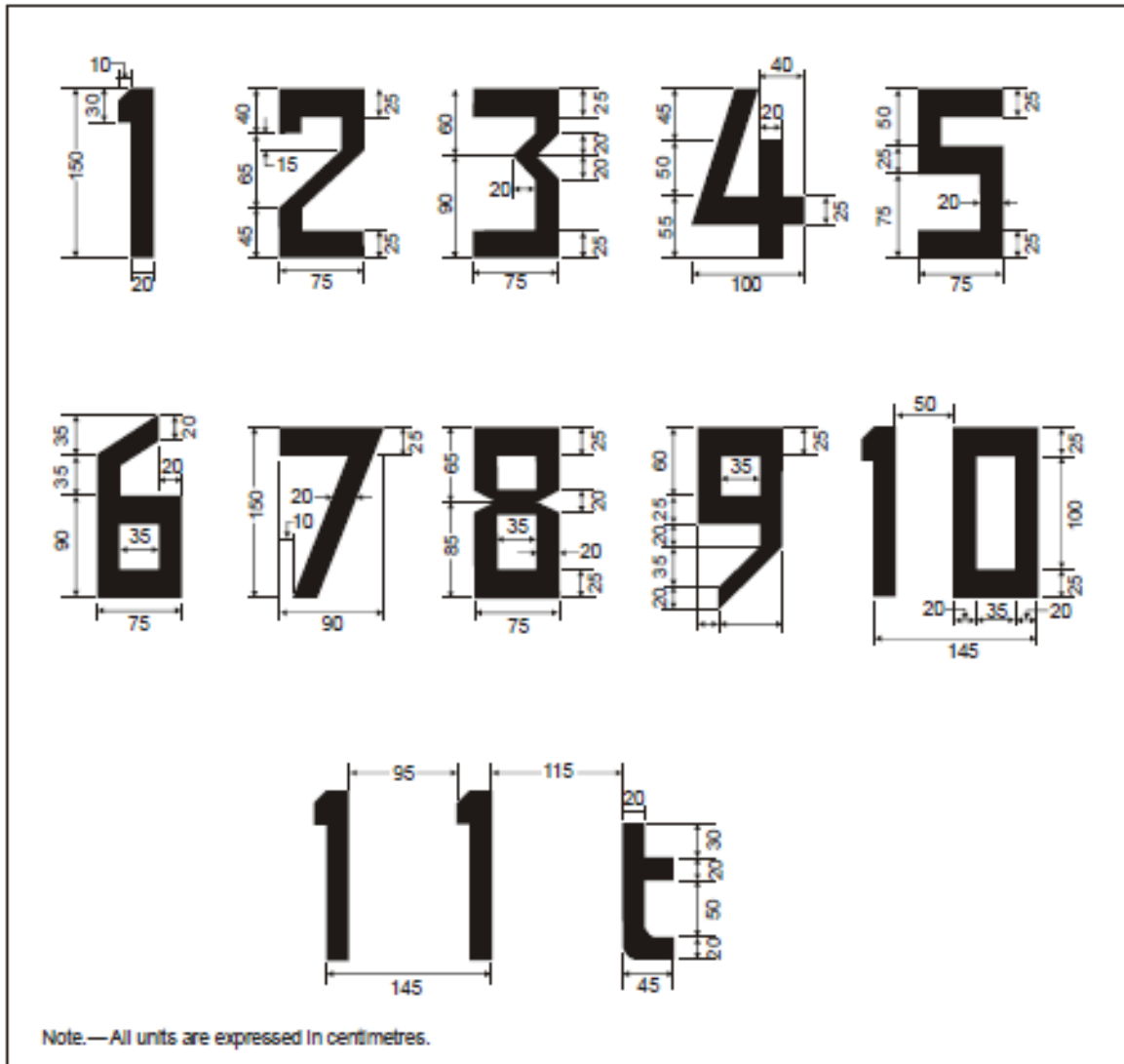

Figure 5-4. Form and proportions of numbers and letters

5.2.4.4 Where there is more than one approach direction, additional D-value markings shall be provided such that at least one D-value marking is readable from the final approach directions. For a non-purpose-built heliport located on a ship’s side, D-value markings shall be provided on the perimeter of the D circle at the 2 o’clock, 10 o’clock and 12 o’clock positions when viewed from the side of the ship facing towards the centre line.

Characteristics

5.2.4.5 The D-value marking shall be white. The D-value marking shall be rounded to the nearest whole metre or foot with 0.5 rounded down.

5.2.4.6 The numbers of the marking shall have a colour contrasting with the background and shall be in the form and proportion shown in Figure 5-4 for a FATO with a dimension of more than 30 m. For a FATO with a dimension of between 15 m to 30 m the height of the numbers of the marking shall be a minimum of 90 cm, and for a FATO with a dimension of less than 15 m the height of the numbers of the marking shall be a minimum of 60 cm, each with a proportional reduction in width and thickness.

5.2.5 Final approach and take-off area dimension(s) marking



Application

5.2.5.1 The actual dimension(s) of the FATO intended to be used by helicopters operated in performance class 1 shall be marked on the FATO.

5.2.5.2 If the actual dimension(s) of the FATO to be used by helicopters operated in performance class 2 or 3 is less than 1 D, the dimension(s) shall be marked on the FATO.

Location

5.2.5.3 A FATO dimension marking shall be located within the FATO and so arranged as to be readable from the preferred final approach direction.

Characteristics

5.2.5.4 The dimension(s) shall be rounded to the nearest metre or foot.

All FATOs except runway-type FATOs

5.2.5.5 The numbers of the marking shall have a colour contrasting with the background and shall be in the form and proportion shown in Figure 5-4 for a FATO with a dimension of more than 30 m. For a FATO with a dimension between 15 m to 30 m the height of the numbers of the marking shall be a minimum of 90 cm, and for a FATO with a dimension of less than 15 m the height of the numbers of the marking shall be a minimum of 60 cm, each with a proportional reduction in width and thickness.

Runway-type FATOs

5.2.5.6 The numbers of the marking shall have a colour contrasting with the background and shall be in the form and proportion shown in Figure 5-4.

5.2.6 Final approach and take-off area perimeter marking or markers for surface-level heliports

Application

5.2.6.1 FATO perimeter marking or markers shall be provided at a surface-level heliport where the extent of the FATO is not self-evident.

Location

5.2.6.2 The FATO perimeter marking or markers shall be located on the edge of the FATO.

Characteristics — Runway-type FATOs

5.2.6.3 The perimeter of the FATO shall be defined with markings or markers spaced at equal intervals of not more than 50 m with at least three markings or markers on each side including a marking or marker at each corner.

5.2.6.4 A FATO perimeter marking shall be a rectangular stripe with a length of 9 m or one-fifth of the side of the FATO which it defines and a width of 1 m.

5.2.6.5 FATO perimeter markings shall be white.

5.2.6.6A FATO perimeter marker shall have dimensional characteristics as shown in Figure 5-5.

5.2.6.7 FATO perimeter markers shall be of colour(s) that contrast effectively against the operating background.

5.2.6.8 FATO perimeter markers shall be a single colour, orange or red, or two contrasting colours, orange and white or, alternatively, red and white shall be used except where such colours would merge with the background.

Characteristics — All FATOs except runway-type FATOs

5.2.6.9 For an unpaved FATO the perimeter shall be defined with flush in-ground markers. The FATO perimeter markers shall be 30 cm in width, 1.5 m in length, and with end-to-end spacing of not less than 1.5 m and not more than 2 m. The corners of a square or rectangular FATO shall be defined.

5.2.6.10 For a paved FATO the perimeter shall be defined with a dashed line. The FATO perimeter marking segments shall be 30 cm in width, 1.5 m in length, and with end-to-end spacing of not less than 1.5 m and not more than 2 m. The corners of the square or rectangular FATO shall be defined.

5.2.6.11 FATO perimeter markings and flush in-ground markers shall be white.

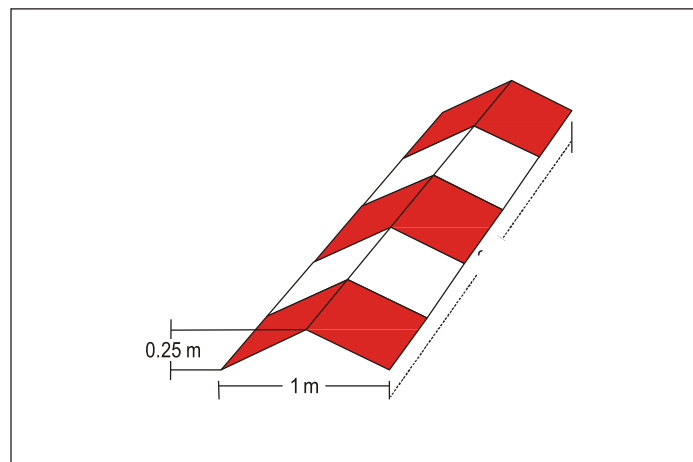

Figure 5-5. Runway-type FATO edge marker

5.2.7 Final approach and take-off area designation markings for runway-type FATOs

Application

5.2.7.1 A FATO designation marking shall be provided at a heliport where it is necessary to designate the FATO to the pilot.

Location

5.2.7.2 A FATO designation marking shall be located at the beginning of the FATO as shown in Figure 5-2.

Characteristics

5.2.7.3A FATO designation marking shall consist of a two-digit number. The two-digit number shall be the whole number nearest the one-tenth of the magnetic North when viewed from the direction of approach. When the above rule would give a single digit number, it shall be preceded by a zero. The marking as shown in Figure 5-2, shall be supplemented by the heliport identification marking.

5.2.8 Aiming point marking

Application

5.2.8.1An aiming point marking shall be provided at a heliport where it is necessary for a pilot to make an approach to a particular point above a FATO before proceeding to a TLOF.

Location — Runway-type FATOs

5.2.8.2The aiming point marking shall be located within the FATO.

Location — All FATOs except runway-type FATOs

5.2.8.3The aiming point marking shall be located at the centre of the FATO as shown in Figure 5-1.

Characteristics

5.2.8.4The aiming point marking shall be an equilateral triangle with the bisector of one of the angles aligned with the preferred approach direction. The marking shall consist of continuous white lines, and the dimensions of the marking shall conform to those shown in Figure 5-6.

5.2.9 Touchdown and lift-off area perimeter marking

Application

5.2.9.1A TLOF perimeter marking shall be displayed on a TLOF located in a FATO at a surface-level heliport if the perimeter of the TLOF is not self-evident.

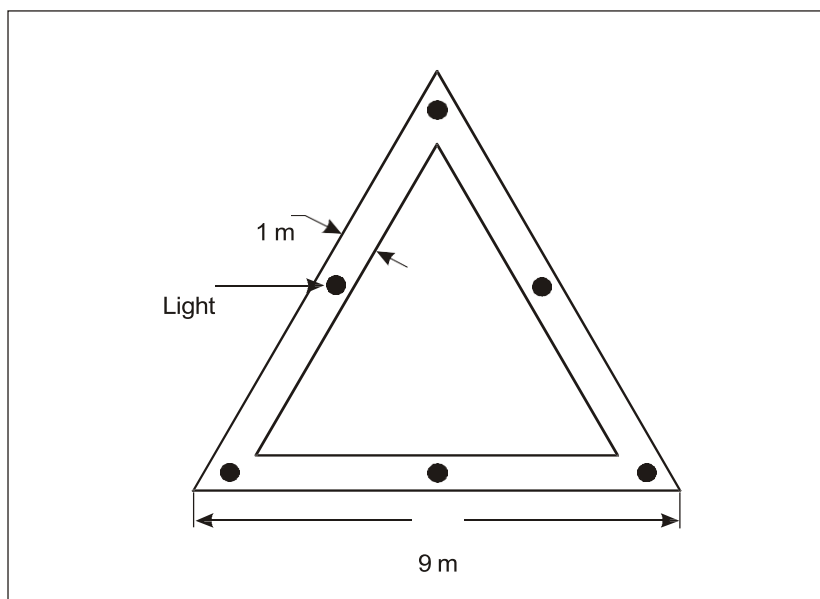

Figure 5-6. Aiming point marking



5.2.9.2A TLOF perimeter marking shall be displayed on an elevated heliport, a helideck and a shipboard heliport.

5.2.9.3 When deemed necessary by the Authority a TLOF perimeter marking should be provided on each TLOF collocated with a helicopter stand at a surface-level heliport.

Location

5.2.9.4 The TLOF perimeter marking shall be located along the edge of the TLOF.

Characteristics

5.2.9.5 A TLOF perimeter marking shall consist of a continuous white line with a width of at least 30 cm.

5.2.10 Touchdown/positioning marking

Application

5.2.10.1 A touchdown/positioning marking shall be provided where it is necessary for a helicopter to touch down and/or be accurately positioned by the pilot. A touchdown/positioning marking shall be provided on a helicopter stand designed for turning.

Location

5.2.10.2 A touchdown/positioning marking shall be located so that when the pilot's seat is over the marking, the whole of the undercarriage will be within the TLOF and all parts of the helicopter will be clear of any obstacle by a safe margin.

5.2.10.3 On a heliport the centre of the touchdown/positioning marking shall be located at the centre of the TLOF, except the centre of the touchdown/positioning marking may be offset away from the centre of the TLOF where an aeronautical study indicates such offsetting to be necessary and providing that a marking so offset would not adversely affect safety. For a helicopter stand designed for hover turning, the touchdown/positioning marking shall be located in the centre of the central zone. (See Figure 3-4.)

5.2.10.4 On a helideck the centre of the touchdown marking shall be located at the centre of the FATO, except that the marking may be offset away from the origin of the obstacle-free sector by no more than 0.1 D where an aeronautical study indicates such offsetting to be necessary and that a marking so offset would not adversely affect the safety.

Characteristics

5.2.10.5 A touchdown/positioning marking shall be a yellow circle and have a line width of at least 0.5 m. For a helideck and a purpose-built shipboard heliport with a D value of 16 m or larger, the line width shall be at least 1 m.

5.2.10.6 The inner diameter of the touchdown/positioning marking shall be 0.5 D of the largest helicopter the TLOF and/or the helicopter stand is intended to serve.

5.2.11 Heliport name marking



Application

5.2.11.1 A heliport name marking shall be provided at a heliport and helideck where there is insufficient alternative means of visual identification.

Location

5.2.11.2 The heliport name marking shall be displayed on the heliport so as to be visible, as far as practicable, at all angles above the horizontal. Where an obstacle sector exists on a helideck the marking shall be located on the obstacle side of the heliport identification marking. For a non-purpose-built heliport located on a ship's side the marking shall be located on the inboard side of the heliport identification marking in the area between the TLOF perimeter marking and the boundary of the LOS.

Characteristics

5.2.11.3 A heliport name marking shall consist of the name or the alphanumeric designator of the heliport as used in the radio (R/T) communications.

5.2.11.4 A heliport name marking intended for use at night or during conditions of poor visibility should be illuminated, either internally or externally.

Runway-type FATOs

5.2.11.5 The characters of the marking shall be not less than 3 m in height.

All FATOs except runway-type FATOs.

5.2.11.6 The characters of the marking shall be not less than 1.5 m in height at surface-level heliports and not less than 1.2 m on elevated heliports, helidecks and shipboard heliports. The colour of the marking shall contrast with the background and preferably be white.

5.2.12 Helideck obstacle-free sector (chevron) marking

Application

5.2.12.1 A helideck with adjacent obstacles that penetrate above the level of the helideck shall have an obstacle-free sector marking.

Location

5.2.12.2 A helideck obstacle-free sector marking shall be located, where practicable, at a distance from the centre of the TLOF equal to the radius of the largest circle that can be drawn in the TLOF or 0.5 D, whichever is greater.

Characteristics

5.2.12.3 The helideck obstacle-free sector marking shall indicate the location of the obstacle-free sector and the directions of the limits of the sector.

5.2.12.4 The height of the chevron shall not be less than 30 cm.

5.2.12.5 The chevron shall be marked in a conspicuous colour.

5.2.12.6 The colour of the chevron shall be black.

5.2.13 Helideck and shipboard heliport surface marking

Application

5.2.13.1 A surface marking shall be provided to assist the pilot to identify the location of the helideck or shipboard heliport during an approach by day.

Location

5.2.13.2 A surface marking shall be applied to the dynamic load bearing area bounded by the TLOF perimeter marking.

Characteristics

5.2.13.3 The helideck or shipboard heliport surface bounded by the TLOF perimeter marking shall be of dark green using a high friction coating.

5.2.14 Helideck prohibited landing sector markings

Application

5.2.14.1 Helideck prohibited landing sector markings shall be provided where it is necessary to prevent the helicopter from landing within specified headings.

Location

5.2.14.2 The prohibited landing sector markings shall be located on the touchdown/positioning marking to the edge of the TLOF, within the relevant headings.

Characteristics

5.2.14.3 The prohibited landing sector markings shall be indicated by white and red hatched markings as shown in Figure 5-7.

5.2.15 Helicopter ground taxiway markings and markers



Figure 5-7. Helideck prohibited landing sector marking***Application***

5.2.15.1 The centre line of a helicopter ground taxiway shall be identified with a marking, and the edges of a helicopter ground taxiway, if not self-evident, shall be identified with markers or markings.

Location

5.2.15.2 Helicopter ground taxiway markings shall be along the centre line and, if required, along the edges of a helicopter ground taxiway.

5.2.15.3 Helicopter ground taxiway edge markers shall be located at a distance of 0.5 m to 3 m beyond the edge of the helicopter ground taxiway.

5.2.15.4 Helicopter ground taxiway edge markers, where provided, shall be spaced at intervals of not more than 15 m on each side of straight sections and 7.5 m on each side of curved sections with a minimum of four equally spaced markers per section.

Characteristics

5.2.15.5 A helicopter ground taxiway centre line marking shall be a continuous yellow line 15 cm in width.

5.2.15.6 Helicopter ground taxiway edge markings shall be a continuous double yellow line, each 15 cm in width, and spaced 15 cm apart (nearest edge to nearest edge).

5.2.15.7 A helicopter ground taxiway edge marker shall be frangible.

5.2.15.8 A helicopter ground taxiway edge marker shall not exceed a plane originating at a height of 25 cm above the plane of the helicopter ground taxiway, at a distance of 0.5 m from the edge of the helicopter ground taxiway and sloping upwards and outwards at a gradient of 5 per cent to a distance of 3 m beyond the edge of the helicopter ground taxiway.

5.2.15.9 A helicopter ground taxiway edge marker shall be blue.

5.2.15.10 If the helicopter ground taxiway is to be used at night, the edge markers shall be internally illuminated or retro-reflective.

5.2.16 Helicopter air taxiway markings and markers***Application***

5.2.16.1 The centre line of a helicopter air taxiway or, if not self-evident, the edges of a helicopter air taxiway shall be identified with markers or markings.

Location

5.2.16.2 A helicopter air taxiway centre line marking or flush in-ground centre line marker shall be located along the centre line of the helicopter air taxiway.



- 5.2.16.3 Helicopter air taxiway edge markings shall be located along the edges of a helicopter air taxiway.
- 5.2.16.4 Helicopter air taxiway edge markers shall be located at a distance of 1 m to 3 m beyond the edge of the helicopter air taxiway.
- 5.2.16.5 Helicopter air taxiway edge markers shall not be located at a distance of less than 0.5 times the largest overall width of the helicopter for which it is designed from the centre line of the helicopter air taxiway.

Characteristics

- 5.2.16.6 A helicopter air taxiway centre line, when on a paved surface, shall be marked with a continuous yellow line 15 cm in width.
- 5.2.16.7 The edges of a helicopter air taxiway, when on a paved surface, shall be marked with continuous double yellow lines each 15 cm in width, and spaced 15 cm apart (nearest edge to nearest edge).
- 5.2.16.8 A helicopter air taxiway centre line, when on an unpaved surface that will not accommodate painted markings, shall be marked with flush in-ground 15 cm wide and approximately 1.5 m in length yellow markers, spaced at intervals of not more than 30 m on straight sections and not more than 15 m on curves, with a minimum of four equally spaced markers per section.
- 5.2.16.9 Helicopter air taxiway edge markers, where provided, shall be spaced at intervals of not more than 30 m on each side of straight sections and not more than 15 m on each side of curves, with a minimum of four equally spaced markers per section.
- 5.2.16.10 Helicopter air taxiway edge markers shall be frangible.
- 5.2.16.11 Helicopter air taxiway edge markers shall not penetrate a plane originating at a height of 25 cm above the plane of the helicopter air taxiway, at a distance of 1 m from the edge of the helicopter air taxiway and sloping upwards and outwards at a gradient of 5 per cent to a distance of 3 m beyond the edge of the helicopter air taxiway.
- 5.2.16.12 Helicopter air taxiway edge markers shall not penetrate a plane originating at a height of 25 cm above the plane of the helicopter air taxiway, at a distance of 0.5 times the largest overall width of the helicopter for which it is designed from the centre line of the helicopter air taxiway, and sloping upwards and outwards at a gradient of 5 per cent.
- 5.2.16.13 A helicopter air taxiway edge marker shall be of colour(s) that contrast effectively against the operating background. The colour red shall not be used for markers.
- 5.2.16.14 If the helicopter air taxiway is to be used at night, helicopter air taxiway edge markers shall be either internally illuminated or retro-reflective.
- 5.2.17 Helicopter stand markings

Application

- 5.2.17.1 A helicopter stand perimeter marking shall be provided on a helicopter stand designed for turning. If a helicopter stand perimeter marking is not practicable, a central zone perimeter marking shall be provided instead if the perimeter of the central zone is not self-evident.
- 5.2.17.2 For a helicopter stand intended to be used for taxi-through and which does not allow the helicopter to turn, a stop line shall be provided.
- 5.2.17.3 Alignment lines and lead-in/lead-out lines shall be provided on a helicopter stand.

Location

- 5.2.17.4 A helicopter stand perimeter marking on a helicopter stand designed for turning or, a central zone perimeter marking, shall be concentric with the central zone of the stand.
- 5.2.17.5 For a helicopter stand intended to be used for taxi-through and which does not allow the helicopter to turn, a stop line shall be located on the helicopter ground taxiway axis at right angles to the centre line.
- 5.2.17.6 Alignment lines and lead-in/lead-out lines shall be located as shown in Figure 5-8.

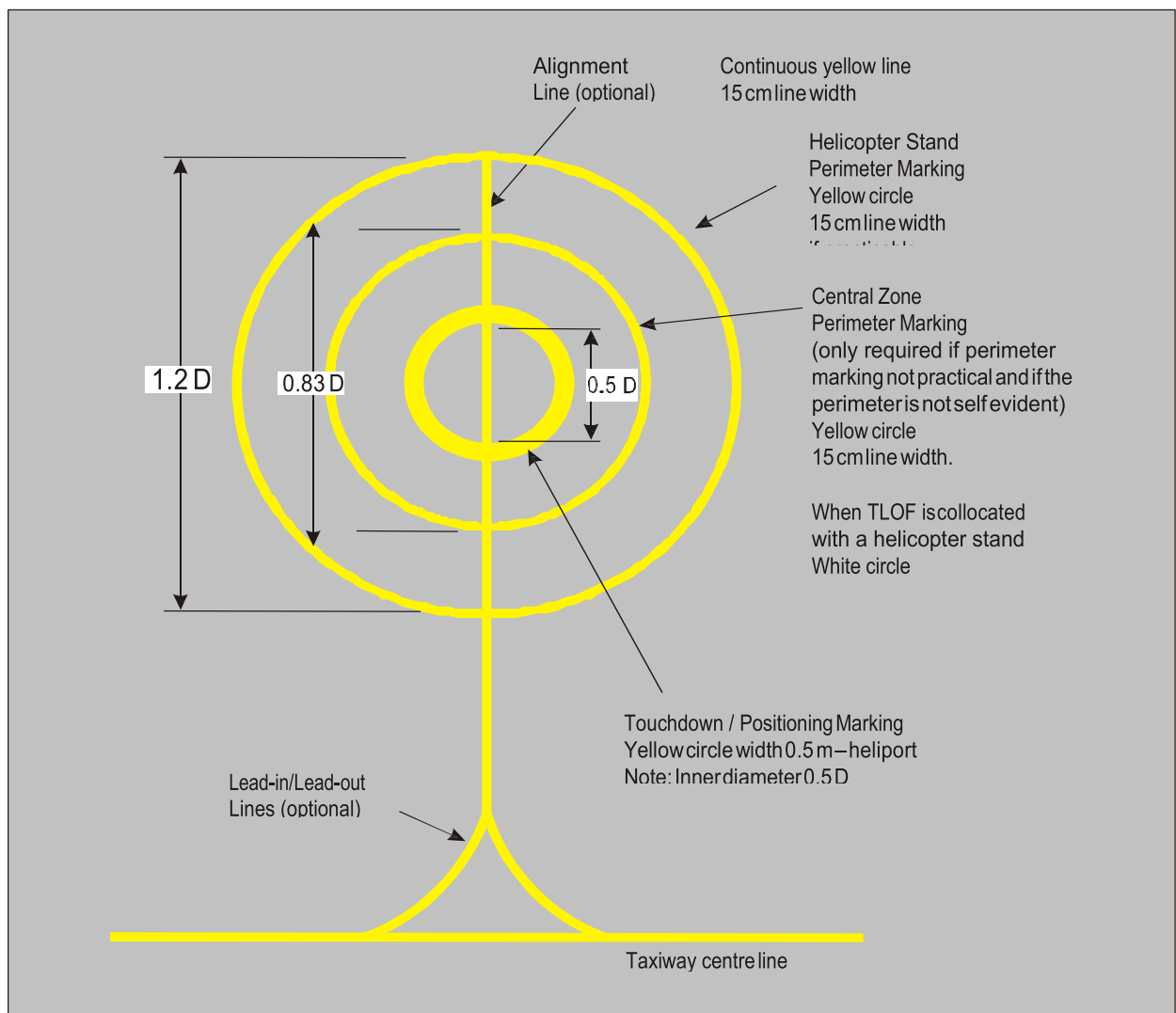

Figure 5-8. Helicopter stand markings



Characteristics

- 5.2.17.7 A helicopter stand perimeter marking shall be a yellow circle and have a line width of 15 cm.
- 5.2.17.8 A central zone perimeter marking shall be a yellow circle and have a line width of 15 cm, except when the TLOF is collocated with a helicopter stand, the characteristics of the TLOF perimeter markings shall apply.
- 5.2.17.9 For a helicopter stand intended to be used for taxi-through and which does not allow the helicopter to turn, a yellow stop line shall not be less than the width of the helicopter ground taxiway and have a line thickness of 50 cm.
- 5.2.17.10 Alignment lines and lead-in/lead-out lines shall be continuous yellow lines and have a width of 15 cm.
- 5.2.17.11 Curved portions of alignment lines and lead-in/lead-out lines shall have radii appropriate to the most demanding helicopter type the helicopter stand is intended to serve.
- 5.2.17.12 Stand identification markings shall be marked in a contrasting colour so as to be easily readable.
- 5.2.18 Flight path alignment guidance marking

Application

- 5.2.18.1 Flight path alignment guidance marking(s) shall be provided at a heliport where it is desirable and practicable to indicate available approach and/or departure path direction(s).

Location

- 5.2.18.2 The flight path alignment guidance marking shall be located in a straight line along the direction of approach and/or departure path on one or more of the TLOF, FATO, safety area or any suitable surface in the immediate vicinity of the FATO or safety area.

Characteristics

- 5.2.18.3 A flight path alignment guidance marking shall consist of one or more arrows marked on the TLOF, FATO and/or safety area surface as shown in Figure 5-9. The stroke of the arrow(s) shall be 50 cm in width and at least 3 m in length. When combined with a flight path alignment guidance lighting system it shall take the form shown in Figure 5-9 which includes the scheme for marking 'heads of the arrows' which are constant regardless of stroke length.
- 5.2.18.4 The markings shall be in a colour which provides good contrast against the background colour of the surface on which they are marked, preferably white.

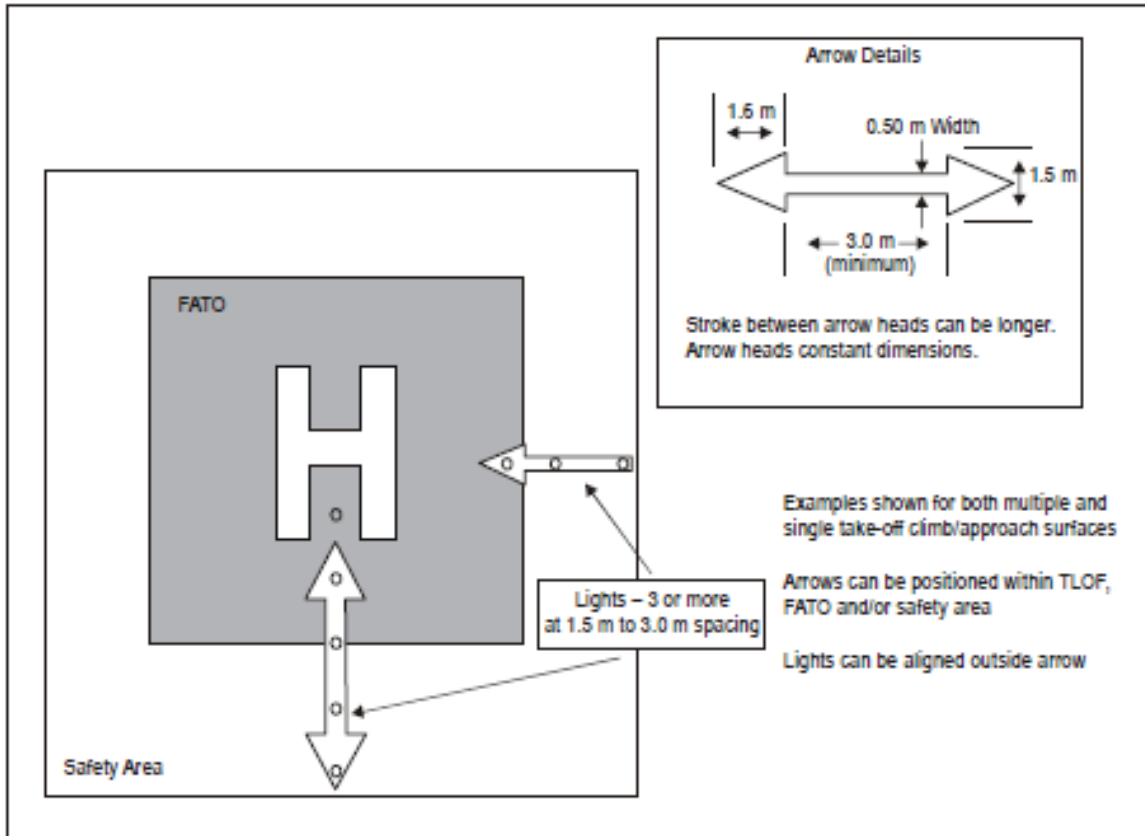

Figure 5-9. Flight path alignment guidance markings and lights

5.3 Lights

5.3.1 General

- (a) In the case of helidecks and heliports located near navigable waters, aeronautical ground lights shall not be sighted as to cause confusion to mariners.
- (b) Extraneous light sources shall be screened or located so as to avoid direct and reflected glare towards helicopters.

Note 1.— See Annex 14, Volume I, 5.3.1, concerning specifications on screening of non-aeronautical ground lights, and design of elevated and inset lights.

Note 2.— Specifications in sections 5.3.4, 5.3.6, 5.3.7, and 5.3.8 are designed to provide effective lighting systems based on night conditions. Where lights are to be used in conditions other than night (i.e. day or twilight) it may be necessary to increase the intensity of the lighting to maintain effective visual cues by use of a suitable brilliancy control. Guidance is provided in the Aerodrome Design Manual (Doc 9157), Part 4 — Visual Aids.

5.3.2 Heliport beacon

Application

5.3.2.1 A heliport beacon shall be provided at a heliport where:

- (a) long-range visual guidance is considered necessary and is not provided by other visual means; or



(b) identification of the heliport is difficult due to surrounding lights.

Location

5.3.2.2 The heliport beacon shall be located on or adjacent to the heliport preferably at an elevated position and so that it does not dazzle a pilot at short range.

Characteristics

5.3.2.3 The heliport beacon shall emit repeated series of equi-spaced short duration white flashes in the format in Figure 5-10.

5.3.2.4 The light from the beacon shall show at all angles of azimuth.

5.3.2.5 The effective light intensity distribution of each flash shall be as shown in Figure 5-11, Illustration 1.

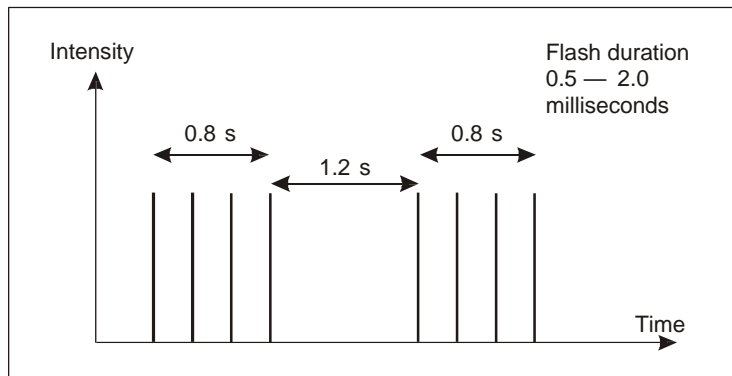

Figure 5-10. Heliport beacon flash characteristics

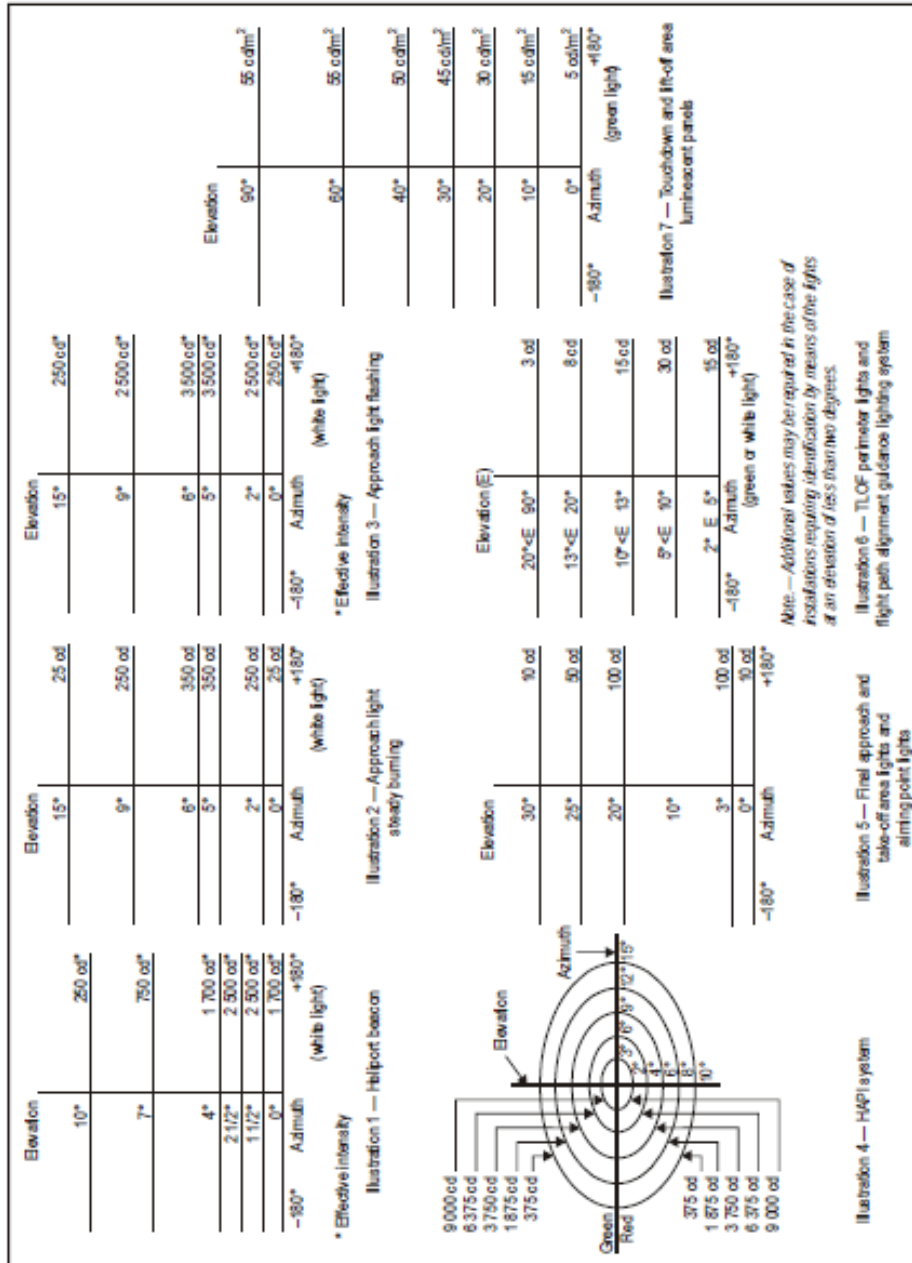

Figure 5-11. Isocandela diagrams

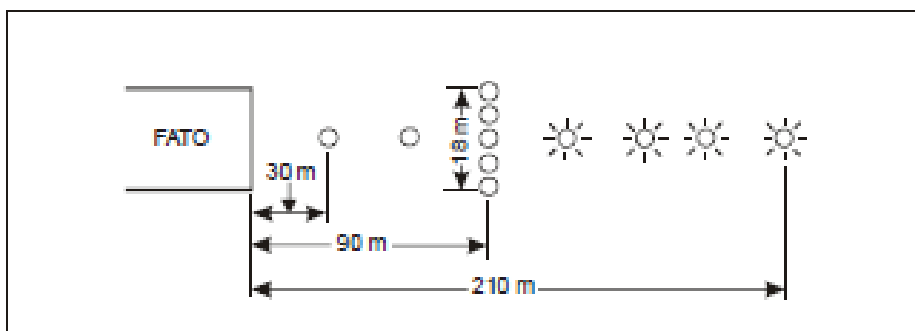

Figure 5-12. Approach lighting system



5.3.3 Approach lighting system

Application

5.3.3.1 Where deemed necessary by the Authority an approach lighting system shall be provided at a heliport where it is desirable and practicable to indicate a preferred approach direction.

Location

5.3.3.2 The approach lighting system shall be located in a straight line along the preferred direction of approach.

Characteristics

5.3.3.3 An approach lighting system shall consist of a row of three lights spaced uniformly at 30 m intervals and of a crossbar 18 m in length at a distance of 90 m from the perimeter of the FATO as shown in Figure 5-12. The lights forming the crossbar shall be as nearly as practicable in a horizontal straight line at right angles to, and bisected by, the line of the centre line lights and spaced at 4.5 m intervals. Where there is the need to make the final approach course more conspicuous, additional lights spaced uniformly at 30 m intervals shall be added beyond the crossbar. The lights beyond the crossbar may be steady or sequenced flashing, depending upon the environment.

5.3.3.4 The steady lights shall be omnidirectional white lights.

5.3.3.5 Sequenced flashing lights shall be omnidirectional white lights.

5.3.3.6 The flashing lights shall have a flash frequency of one per second and their light distribution shall be as shown in Figure 5-11, Illustration 3. The flash sequence shall commence from the outermost light and progress towards the crossbar.

5.3.3.7 A suitable brilliancy control shall be incorporated to allow for adjustment of light intensity to meet the prevailing conditions.

Note: The following intensity settings have been found suitable:

- (a) steady lights — 100 per cent, 30 per cent and 10 per cent; and
- (b) flashing lights — 100 per cent, 10 per cent and 3 per cent.

5.3.4 Flight path alignment guidance lighting system

Application

5.3.4.1 Flight path alignment guidance lighting system(s) shall be provided at a heliport where it is desirable and practicable to indicate available approach and/or departure path direction(s).

Location

5.3.4.2 The flight path alignment guidance lighting system shall be in a straight line along the direction(s) of approach and/or departure path on one or more of the TLOF, FATO, safety area or any suitable surface in the immediate vicinity of the FATO, TLOF or safety area.



5.3.4.3 If combined with a flight path alignment guidance marking, the lights shall be located inside the “arrow” markings.

Characteristics

5.3.4.4 A flight path alignment guidance lighting system shall consist of a row of three or more lights spaced uniformly a total minimum distance of 6 m. Intervals between lights should not be less than 1.5 m and should not exceed 3 m. Where space permits there should be 5 lights. (See Figure 5-9.)

5.3.4.5 The lights shall be steady omnidirectional inset white lights.

5.3.4.6 The distribution of the lights shall be as indicated in Figure 5-11, Illustration 6.

5.3.4.7 A suitable control should be incorporated to allow for adjustment of light intensity to meet the prevailing conditions and to balance the flight path alignment guidance lighting system with other heliport lights and general lighting that may be present around the heliport.

5.3.5 Visual alignment guidance system

Application

5.3.5.1 A visual alignment guidance system shall be provided to serve the approach to a heliport where one or more of the following conditions exist especially at night:

- (a) obstacle clearance, noise abatement or traffic control procedures require a particular direction to be flown;
- (b) the environment of the heliport provides few visual surface cues; and
- (c) it is physically impracticable to install an approach lighting system.

Location

5.3.5.2 The visual alignment guidance system shall be located such that a helicopter is guided along the prescribed track towards the FATO.

5.3.5.3 The system shall be located at the downwind edge of the FATO and aligned along the preferred approach direction.

5.3.5.4 The light units shall be frangible and mounted as low as possible.

5.3.5.5 Where the lights of the system need to be seen as discrete sources, light units shall be located such that at the extremes of system coverage the angle subtended between units as seen by the pilot shall not be less than 3 minutes of arc.

5.3.5.6 The angles subtended between light units of the system and other units of comparable or greater intensities shall also be not less than 3 minutes of arc.

Signal format

5.3.5.7 The signal format of the alignment guidance system shall include a minimum of three discrete signal sectors providing “offset to the right”, “on track” and “offset to the left” signals.

- 5.3.5.8 The divergence of the “on track” sector of the system shall be as shown in Figure 5-13.
- 5.3.5.9 The signal format shall be such that there is no possibility of confusion between the system and any associated visual approach slope indicator or other visual aids.
- 5.3.5.10 The system shall avoid the use of the same coding as any associated visual approach slope indicator.
- 5.3.5.11 The signal format shall be such that the system is unique and conspicuous in all operational environments.
- 5.3.5.12 The system shall not significantly increase the pilot workload.

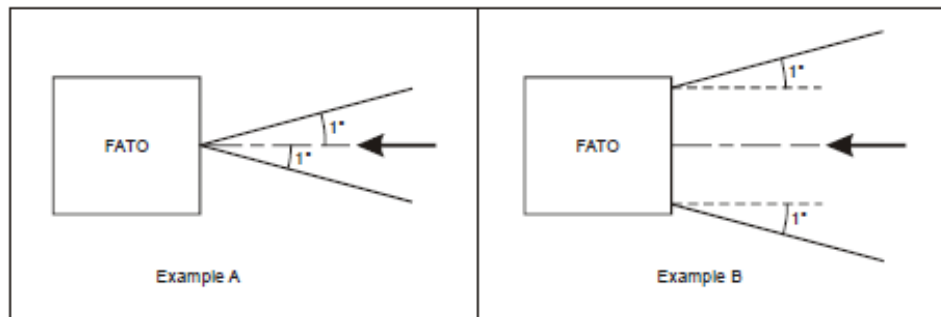

Figure 5-13. Divergence of the “on track” sector

Light distribution

- 5.3.5.13 The usable coverage of the visual alignment guidance system shall be equal to or better than that of the visual approach slope indicator system with which it is associated.
- 5.3.5.14 A suitable intensity control shall be provided so as to allow adjustment to meet the prevailing conditions and to avoid dazzling the pilot during approach and landing.

Approach track and azimuth setting

- 5.3.5.15 A visual alignment guidance system shall be capable of adjustment in azimuth to within ± 5 minutes of arc of the desired approach path.
- 5.3.5.16 The angle of the azimuth guidance system shall be such that during an approach the pilot of a helicopter at the boundary of the “on track” signal will clear all objects in the approach area by a safe margin.
- 5.3.5.17 The characteristics of the obstacle protection surface specified in 5.3.6.23, Table 5-1 and Figure 5-14 shall equally apply to the system.

Characteristics of the visual alignment guidance system

- 5.3.5.18 In the event of the failure of any component affecting the signal format the system shall be automatically switched off.
- 5.3.5.19 The light units shall be so designed that deposits of condensation, ice, dirt, etc., on optically transmitting or reflecting surfaces will interfere to the least possible extent with the light signal and will not cause spurious or false signals to be generated.

Table 5-1. Dimensions and slopes of the obstacle protection surface

SURFACE AND DIMENSIONS	FATO	
Length of inner edge	Width of safety area	
Distance from end of FATO	3 m minimum	
Divergence	10%	
Total length	2 500 m	
Slope	PAPI	$A^a - 0.57^\circ$
	HAPI	$A^b - 0.65^\circ$
	APAPI	$A^a - 0.9^\circ$
a. As indicated in CAR AGA 1, Figure 5-19. b. The angle of the upper boundary of the “below slope” signal.		

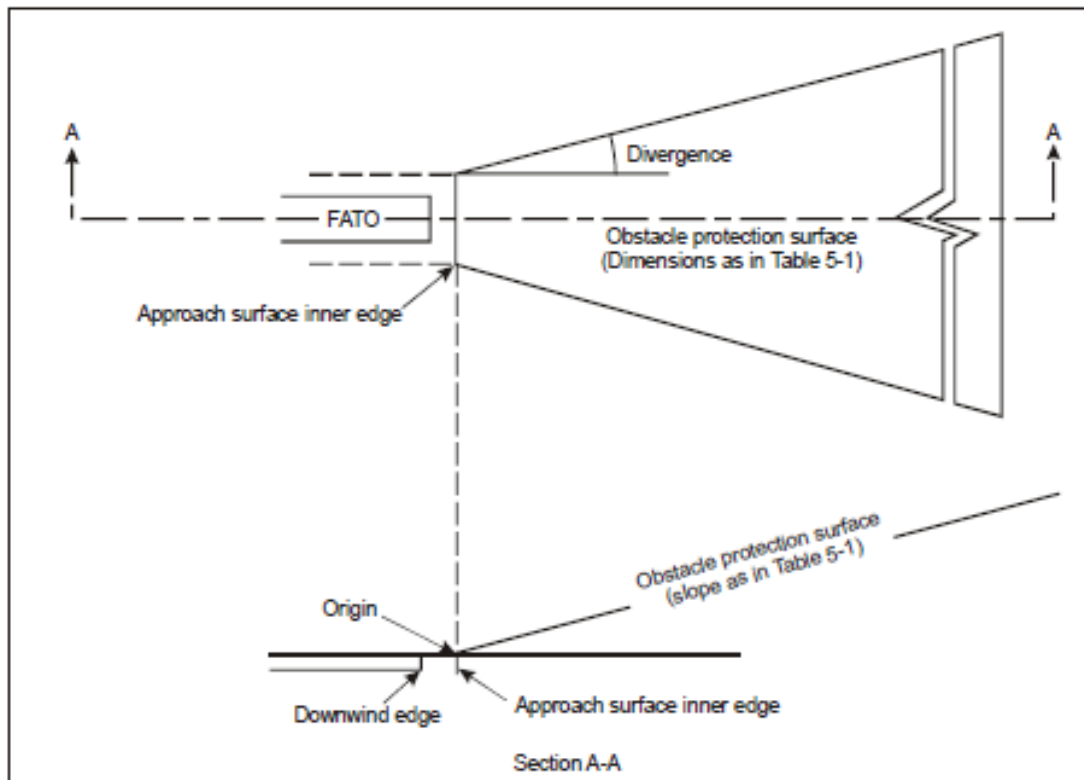

Figure 5-14. Obstacle protection surface for Visual Approach Slope Indicator Systems

5.3.6 Visual Approach Slope Indicator

Application

5.3.6.1A Visual Approach Slope Indicator shall be provided to serve the approach to a heliport, whether or not the heliport is served by other visual approach aids or by non-visual aids, where one or more of the following conditions exist especially at night:

- (a) obstacle clearance, noise abatement or traffic control procedures require a particular slope to be flown;



- (b) the environment of the heliport provides few visual surface cues; and
- (c) the characteristics of the helicopter require a stabilized approach.

5.3.6.2 The standard Visual Approach Slope Indicator Systems for helicopter operations shall consist of the following:

- (a) PAPI and APAPI systems conforming to the specifications contained in CAR AGA 1, 5.3.5.23 to 5.3.5.40 inclusive, except that the angular size of the on-slope sector of the systems shall be increased to 45 minutes; or
- (b) Helicopter Approach Path Indicator (HAPI) system conforming to the specifications in 5.3.6.6 to 5.3.6.21 inclusive.

Location

5.3.6.3 A Visual Approach Slope Indicator shall be located such that a helicopter is guided to the desired position within the FATO and so as to avoid dazzling the pilot during final approach and landing.

5.3.6.4 A Visual Approach Slope Indicator should be located adjacent to the nominal aiming point and aligned in azimuth with the preferred approach direction.

5.3.6.5 The light unit(s) shall be frangible and mounted as low as possible.

HAPI signal format

5.3.6.6 The signal format of the HAPI shall include four discrete signal sectors, providing an “above slope”, an “on slope”, a “slightly below” and a “below slope” signal.

5.3.6.7 The signal format of the HAPI shall be as shown in Figure 5-15, Illustrations A and B.

5.3.6.8 The signal repetition rate of the flashing sector of the HAPI shall be at least 2 Hz.

5.3.6.9 The on-to-off ratio of pulsing signals of the HAPI shall be 1 to 1, and the modulation depth shall be at least 80 per cent.

5.3.6.10 The angular size of the “on-slope” sector of the HAPI shall be 45 minutes.

5.3.6.11 The angular size of the “slightly below” sector of the HAPI shall be 15 minutes.

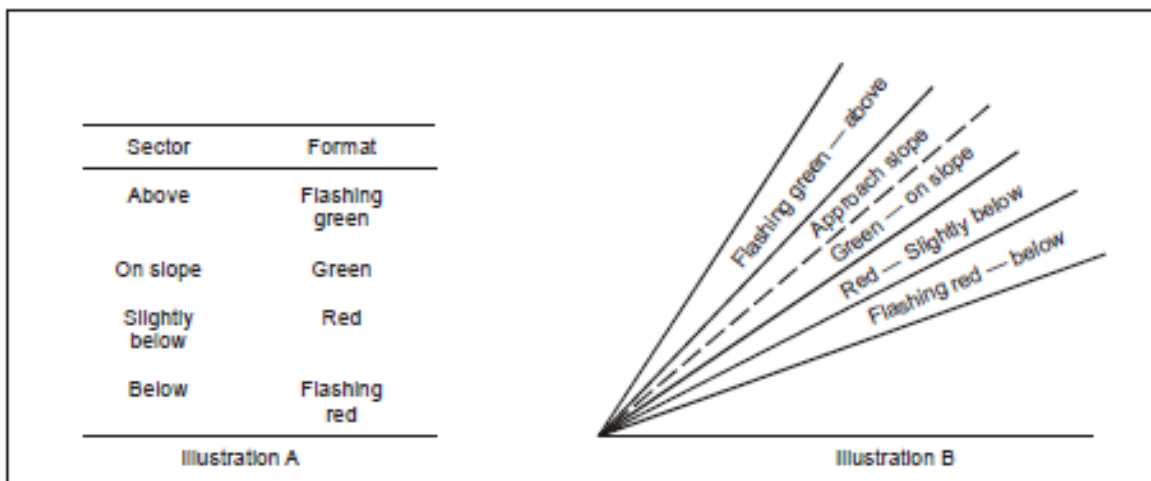

**Figure 5-15. HAPI signal format*****Light distribution***

- 5.3.6.12 The light intensity distribution of the HAPI in red and green colours shall be as shown in Figure 5-11, Illustration 4.
- 5.3.6.13 Colour transition of the HAPI in the vertical plane shall be such as to appear to an observer at a distance of not less than 300 m to occur within a vertical angle of not more than three minutes.
- 5.3.6.14 The transmission factor of a red or green filter shall be not less than 15 per cent at the maximum intensity setting.
- 5.3.6.15 At full intensity the red light of the HAPI shall have a Y-coordinate not exceeding 0.320, and the green light shall be within the boundaries specified in CAR AGA, Volume I, Appendix 1, 2.1.3.
- 5.3.6.16 A suitable intensity control shall be provided so as to allow adjustment to meet the prevailing conditions and to avoid dazzling the pilot during approach and landing.

Approach slope and elevation setting

- 5.3.6.17 A HAPI system shall be capable of adjustment in elevation at any desired angle between 1 degree and 12 degrees above the horizontal with an accuracy of ± 5 minutes of arc.
- 5.3.6.18 The angle of elevation setting of HAPI shall be such that during an approach, the pilot of a helicopter observing the upper boundary of the “below slope” signal will clear all objects in the approach area by a safe margin.

Characteristics of the light unit

- 5.3.6.19 The system shall be so designed that:
- in the event the vertical misalignment of a unit exceeds ± 0.5 degrees (± 30 minutes), the system will switch off automatically; and
 - if the flashing mechanism fails, no light will be emitted in the failed flashing sector(s).
- 5.3.6.20 The light unit of the HAPI shall be so designed that deposits of condensation, ice, dirt, etc., on optically transmitting or reflecting surfaces will interfere to the least possible extent with the light signal and will not cause spurious or false signals to be generated.
- 5.3.6.21 A HAPI system intended for installation on a floating helideck shall afford a stabilization of the beam to an accuracy of $\pm 1/4$ degree within ± 3 -degree pitch and roll movement of the heliport.

Obstacle protection surface

- 5.3.6.22 An obstacle protection surface shall be established when it is intended to provide a visual approach slope indicator system.
- 5.3.6.23 The characteristics of the obstacle protection surface, i.e. origin, divergence, length and slope, shall correspond to those specified in the relevant column of Table 5-1 and in Figure 5-14.



- 5.3.6.24 New objects or extensions of existing objects shall not be permitted above an obstacle protection surface except when, in the opinion of the appropriate authority, the new object or extension would be shielded by an existing immovable object.
- 5.3.6.25 Existing objects above an obstacle protection surface shall be removed except when, in the opinion of the appropriate authority, the object is shielded by an existing immovable object, or after aeronautical study it is determined that the object would not adversely affect the safety of operations of helicopters.
- 5.3.6.26 Where an aeronautical study indicates that an existing object extending above an obstacle protection surface could adversely affect the safety of operations of helicopters, one or more of the following measures shall be taken:
- suitably raise the approach slope of the system;
 - reduce the azimuth spread of the system so that the object is outside the confines of the beam;
 - displace the axis of the system and its associated obstacle protection surface by no more than 5 degrees;
 - suitably displace the FATO; and
 - install a visual alignment guidance system specified in 5.3.5.

5.3.7 Final Approach and Take-Off area lighting systems for surface-level heliports

Application

5.3.7.1 Where a FATO is established at a surface-level heliport on ground intended for use at night, FATO lights shall be provided except that they may be omitted where the FATO and the TLOF are nearly coincidental or the extent of the FATO is self-evident.

Location

5.3.7.2 FATO lights shall be placed along the edges of the FATO. The lights shall be uniformly spaced as follows:

- for an area in the form of a square or rectangle, at intervals of not more than 50 m with a minimum of four lights on each side including a light at each corner; and
- for any other shaped area, including a circular area, at intervals of not more than 5 m with a minimum of ten lights.

Characteristics

5.3.7.3 FATO lights shall be fixed omnidirectional lights showing white. Where the intensity of the lights is to be varied the lights shall show variable white.

5.3.7.4 The light distribution of FATO lights shall be as shown in Figure 5-11, Illustration 5.

5.3.7.5 The lights shall not exceed a height of 25 cm and should be inset when a light extending above the surface would endanger helicopter operations. Where a FATO is not meant for lift-off or touchdown, the lights shall not exceed a height of 25 cm above ground level.



5.3.8 Aiming point lights

Application

5.3.8.1 Where an aiming point marking is provided at a heliport intended for use at night, aiming point lights shall be provided.

Location

5.3.8.2 Aiming point lights shall be collocated with the aiming point marking.

Characteristics

5.3.8.3 Aiming point lights shall form a pattern of at least six omnidirectional white lights as shown in Figure 5-6. The lights shall be inset when a light extending above the surface could endanger helicopter operations.

5.3.8.4 The light distribution of aiming point lights should be as shown in Figure 5-11, Illustration 5.

5.3.9 Touchdown and Lift-off Area (TOLA) lighting system

Application

5.3.9.1 A TLOF lighting system shall be provided at a heliport intended for use at night.

5.3.9.2 The TLOF lighting system for a surface-level heliport shall consist of one or more of the following:

- (a) perimeter lights; or
- (b) floodlighting; or
- (c) Arrays of Segmented Point Source Lighting (ASPSL) or luminescent panel (LP) lighting to identify the TLOF when a) and b) are not practicable and FATO lights are available.

5.3.9.3 The TLOF lighting system for an elevated heliport or helideck shall consist of:

- (a) perimeter lights; and
- (b) ASPSL and/or LPs to identify the touchdown marking where it is provided and/or floodlighting to illuminate the TLOF.

5.3.9.4 TLOF ASPSL and/or LPs to identify the touchdown marking and/ or floodlighting should be provided at a surface-level heliport intended for use at night when enhanced surface texture cues are required.

Location

5.3.9.5 TLOF perimeter lights shall be placed along the edge of the area designated for use as the TLOF or within a distance of 1.5 m from the edge. Where the TLOF is a circle the lights shall be:

- (a) located on straight lines in a pattern which will provide information to pilots on drift displacement; and



- (b) where a) is not practicable, evenly spaced around the perimeter of the TLOF at the appropriate interval, except that over a sector of 45 degrees the lights shall be spaced at half spacing.

5.3.9.6 TLOF perimeter lights shall be uniformly spaced at intervals of not more than 3 m for elevated heliports and helidecks and not more than 5 m for surface-level heliports. There shall be a minimum number of four lights on each side including a light at each corner. For a circular TLOF, where lights are installed in accordance with 5.3.9.5 b) there shall be a minimum of fourteen lights.

5.3.9.7 The TLOF perimeter lights shall be installed at an elevated heliport or fixed helideck such that the pattern cannot be seen by the pilot from below the elevation of the TLOF.

5.3.9.8 The TLOF perimeter lights shall be installed at a floating helideck, such that the pattern cannot be seen by the pilot from below the elevation of the TLOF when the helideck is level.

5.3.9.9 On surface-level heliports, ASPSL or LPs, if provided to identify the TLOF, shall be placed along the marking designating the edge of the TLOF. Where the TLOF is a circle, they shall be located on straight lines circumscribing the area.

5.3.9.10 On surface-level heliports the minimum number of LPs on a TLOF shall be nine. The total length of LPs in a pattern shall not be less than 50 per cent of the length of the pattern. There shall be an odd number with a minimum number of three panels on each side of the TLOF including a panel at each corner. LPs shall be uniformly spaced with a distance between adjacent panel ends of not more than 5 m on each side of the TLOF.

5.3.9.11 When LPs are used on an elevated heliport or helideck to enhance surface texture cues, the panels shall not be placed adjacent to the perimeter lights. They should be placed around a touchdown marking where it is provided or coincident with heliport identification marking.

5.3.9.12 TLOF floodlights shall be located so as to avoid glare to pilots in flight or to personnel working on the area. The arrangement and aiming of floodlights shall be such that shadows are kept to a minimum.

Characteristics

5.3.9.13 The TLOF perimeter lights shall be fixed omnidirectional lights showing green.

5.3.9.14 At a surface-level heliport, ASPSL or LPs shall emit green light when used to define the perimeter of the TLOF.

5.3.9.15 The chromaticity and luminance of colours of LPs should conform to ICAO Annex 14, Volume I, Appendix 1, 3.4.

5.3.9.16 An LP shall have a minimum width of 6 cm. The panel housing shall be the same colour as the marking it defines.

5.3.9.17 The perimeter lights shall not exceed a height of 25 cm and shall be inset when a light extending above the surface could endanger helicopter operations.

5.3.9.18 When located within the safety area of a heliport or within the obstacle-free sector of a helideck, the TLOF floodlights should not exceed a height of 25 cm.



- 5.3.9.19 The LPs shall not extend above the surface by more than 2.5 cm.
- 5.3.9.20 The light distribution of the perimeter lights shall be as shown in Figure 5-11, Illustration 6.
- 5.3.9.21 The light distribution of the LPs shall be as shown in Figure 5-11, Illustration 7.
- 5.3.9.22 The spectral distribution of TLOF area floodlights shall be such that the surface and obstacle marking can be correctly identified.
- 5.3.9.23 The average horizontal illuminance of the floodlighting shall be at least 10 lux, with a uniformity ratio (average to minimum) of not more than 8:1 measured on the surface of the TLOF.
- 5.3.9.24 Lighting used to identify the touchdown marking shall comprise a segmented circle of omnidirectional ASPSL strips showing yellow. The segments shall consist of ASPSL strips, and the total length of the ASPSL strips shall not be less than 50 per cent of the circumference of the circle.
- 5.3.9.25 If utilized, the heliport identification marking lighting shall be omnidirectional showing green.

5.3.10 Winching area floodlighting

Application

- 5.3.10.1 Winching area floodlighting shall be provided at a winching area intended for use at night.

Location

- 5.3.10.2 Winching area floodlights shall be located so as to avoid glare to pilots in flight or to personnel working on the area. The arrangement and aiming of floodlights shall be such that shadows are kept to a minimum.

Characteristics

- 5.3.10.3 The spectral distribution of winching area floodlights shall be such that the surface and obstacle markings can be correctly identified.
- 5.3.10.4 The average horizontal illuminance shall be at least 10 lux, measured on the surface of the winching area.

5.3.11 Taxiway lights

- 5.3.11.1 The specifications for taxiway centre line lights and taxiway edge lights in CAR AGA 1, 5.3.17 and 5.3.18, shall equally apply to taxiways intended for ground taxiing of helicopters.

5.3.12 Visual aids for denoting obstacles

- 5.3.12.1 The specifications for marking and lighting of obstacles included in CAR AGA ,1 Chapter 6 shall equally apply to heliports and winching areas.

5.3.13 Floodlighting of obstacles

***Application***

5.3.13.1 At a heliport intended for use at night, obstacles shall be floodlighted if it is not possible to display obstacle lights on them.

Location

5.3.13.2 Obstacle floodlights shall be arranged so as to illuminate the entire obstacle and as far as practicable in a manner so as not to dazzle the helicopter pilots.

Characteristics

5.3.13.3 Obstacle floodlighting shall be such as to produce a luminance of at least 10 cd/m^2 .



CHAPTER 6

HELIPORT EMERGENCY RESPONSE

6.1 Heliport Emergency Planning

Note: Heliport emergency planning is the process of preparing a heliport to cope with an emergency that takes place at the heliport or in its vicinity. Examples of emergencies include crashes on or off the heliport, medical emergencies, dangerous goods occurrences, fires and natural disasters.

The purpose of heliport emergency planning is to minimize the impact of an emergency by saving lives and maintaining helicopter operations.

The heliport emergency plan sets out the procedures for coordinating the response of heliport agencies or services (air traffic services unit, firefighting services, heliport administration, medical and ambulance services, aircraft operators, security services and police) and the response of agencies in the surrounding community (fire departments, police, medical and ambulance services, hospitals, military, and harbour patrol or coast guard) that could be of assistance in responding to the emergency.

- 6.1.1 A heliport emergency plan shall be established commensurate with the helicopter operations and other activities conducted at the heliport.
- 6.1.2 The plan shall identify agencies which could be of assistance in responding to an emergency at the heliport or in its vicinity.
- 6.1.3 The heliport emergency plan shall provide for the coordination of the actions to be taken in the event of an emergency occurring at a heliport or in its vicinity.
- 6.1.4 Where an approach/departure path at a heliport is located over water, the plan shall identify which agency is responsible for coordinating rescue in the event of a helicopter ditching and indicate how to contact that agency.
- 6.1.5 The plan shall include, as a minimum, the following information:
 - (a) the types of emergencies planned for;
 - (b) how to initiate the plan for each emergency specified;
 - (c) the name of agencies on and off the heliport to contact for each type of emergency with telephone numbers or other contact information;
 - (d) the role of each agency for each type of emergency;
 - (e) a list of pertinent on-heliport services available with telephone numbers or other contact information;
 - (f) copies of any written agreements with other agencies for mutual aid and the provision of emergency services; and
 - (g) a grid map of the heliport and its immediate vicinity.
- 6.1.6 All agencies identified in the plan shall be consulted about their role in the plan.



6.1.7 The plan shall be reviewed and the information in it updated at least yearly or, if deemed necessary, after an actual emergency, so as to correct any deficiency found during actual emergency.

6.1.8 A test of the emergency plan shall be carried out at least once every three years.

6.2 Rescue and firefighting

Level of protection to be provided

6.2.1 The level of protection to be provided for rescue and firefighting shall be based on the overall length of the longest helicopter normally using the heliport and in accordance with the heliport firefighting category determined from Table 6-1, except at an unattended heliport with a low movement rate.

Table 6-1. Heliport firefighting category

Category	Helicopter overall length ^a
H1	up to but not including 15 m
H2	from 15 m up to but not including 24 m
H3	from 24 m up to but not including 35 m

a. Helicopter length, including the tail boom and the rotors.

6.2.2 During anticipated periods of operations by smaller helicopters, the heliport firefighting category may be reduced to that of the highest category of helicopter planned to use the heliport during that time.

Extinguishing agents

6.2.3 The principal extinguishing agent shall be a foam meeting the minimum performance level B.

6.2.4 The amounts of water for foam production and the complementary agents to be provided shall be in accordance with the heliport firefighting category determined under 6.1.1 and Table 6-2 or Table 6-3, as appropriate.

Table 6-2. Minimum usable amounts of extinguishing agents for surface-level heliports

Category	Foam meeting performance level B		Complementary agents				
	Water (L)	Discharge rate foam solution (L/min)	Dry chemical powders (kg)	or	Halons (kg)	or	CO ₂ (kg)
(1)	(2)	(3)	(4)		(5)		(6)
H1	500	250	23		23		45
H2	1 000	500	45		45		90
H3	1 600	800	90		90		180

Table 6-3. Minimum usable amounts of extinguishing agents for elevated heliports



Category	Foam meeting performance level B		Complementary agents				
	Water (L)	Discharge rate foam solution (L/min)	Dry chemical powders (kg)	or	Halons (kg)	or	CO ₂ (kg)
(1)	(2)	(3)	(4)		(5)		(6)
H1	2 500	250	45		45		90
H2	5 000	500	45		45		90
H3	8 000	800	45		45		90

- 6.2.5 At a surface-level heliport it is permissible to replace all or part of the amount of water for foam production by complementary agents.
- 6.2.6 The discharge rate of the foam solution shall not be less than the rates shown in Table 6-2 or Table 6-3, as appropriate. The discharge rate of complementary agents shall be selected for optimum effectiveness of the agent used.
- 6.2.7 At an elevated heliport, at least one hose spray line capable of delivering foam in a jet spray pattern at 250 L/min shall be provided. Additionally at elevated heliports in categories 2 and 3, at least two monitors shall be provided each having a capability of achieving the required discharge rate and positioned at different locations around the heliports so as to ensure the application of foam to any part of the heliport under any weather condition and to minimize the possibility of both monitors being impaired by a helicopter accident.

Rescue equipment

- 6.2.8 At an elevated heliport, rescue equipment shall be stored adjacent to the heliport.

Response time

- 6.2.9 At a surface-level heliport, the operational objective of the rescue and firefighting service shall be to achieve response times not exceeding two minutes in optimum conditions of visibility and surface conditions.
- 6.2.10 At an elevated heliport, the rescue and firefighting service shall be immediately available on or in the vicinity of the heliport while helicopter movements are taking place.



This Page Intentionally Left Blank

**CHAPTER 7****CERTIFICATION PROCESS****7.1 General requirements for certification**

(See AC 7.1)

- 7.1.1 A heliport operator shall apply to the Authority at least 90 days prior to proposed commencement of helicopter operations.
- 7.1.2 The heliport operator must satisfy the Authority that;
- (a) its organisation and management are suitable and properly matched to the scale and scope of the operation; and
 - (b) procedures for the supervision of operations have been defined
- 7.1.3 A heliport operator shall not provide any heliport related service otherwise than under, and in accordance with, the terms and conditions of a heliport certificate from the Authority.
- 7.1.4 An applicant for a heliport certificate, or variation of a heliport certificate, shall allow the Authority to examine all safety aspects of the proposed service.
- 7.1.5 An applicant for a heliport certificate, or revalidation of the heliport certificate; shall
- (a) have his principal place of business and, if any, his registered office located in The Bahamas; and
 - (b) satisfy the Authority that he is able to conduct safe services.
- 7.1.6 The heliport certificate shall engage and/or employ the services of;
- (a) an Accountable Manager who has the authority within the organisation to ensure that each of the ATS units can be financed and properly organised, equipped and trained to meet the requirements of these regulations; and
 - (b) Sufficient personnel to manage, supervise, provide and support the heliport and any associated training or assessment processes agreed with and approved by the Authority
- 7.1.7 The persons listed in 7.1.6 shall be shall be responsible to the Accountable Manager and approved by the Authority. (See AC 7.1.7)
- 7.1.8 An applicant for a heliport certificate shall establish a safety management system, which is;
- (a) in accordance with the framework elements contained CAR SMS;
 - (b) commensurate with the size of the service provided and the complexity of its aviation products or services; and
 - (c) be made acceptable to the Authority as the State responsible for the heliport's certification.



7.2 Grant of a heliport certificate

(See AC 7.2)

7.2.1 The Authority shall issue the heliport certificate provided:

- (a) The applicant has satisfactorily completed the technical certification process;
- (b) The applicant and his staff have demonstrated the necessary competence and experience to operate and maintain the heliport safely;
- (c) The heliport operating manual submitted by the applicant for approval contains all the relevant information corresponding to the heliport site, facilities, services, equipment, operating procedures, organisation and management as stated in this regulation;
- (d) The heliport facilities, services and equipment are in accordance with the relevant CAR;
- (e) The heliport operating procedures make satisfactory provision for the safety of helicopters; and
- (f) The applicant has implemented an acceptable SMS.

7.2.2 Any conditions or limitations stated on the heliport certificate shall be complied with.

7.3 Duration of a heliport certificate

7.3.1 A heliport certificate issued under CAR AGA 2 shall remain in force from the date of issue until it is suspended, transferred or cancelled by the Authority or, alternatively, until the validity period has expired.

7.3.2 A heliport certificate shall be valid for a maximum period of 5 years.

7.3.3 Any renewals of the heliport certificate shall be subject to approval by the Authority.

7.3.4 The Authority may revoke a heliport certificate if during the surveillance process The heliport operator does not demonstrate that it maintains the necessary competencies or if it incurs in recurring failures in the resolution of any non-conformities found.

7.4 Transfer of a heliport certificate

7.4.1 The Authority may give its consent to and issue an instrument of transfer of a heliport certificate to a transferee when:

- (a) The current holder of the heliport certificate notifies the Authority, in writing, at least three months before ceasing to operate the heliport as of the date specified in the notice, including the name of the transferee or heliport operator.
- (b) The transferee applies to the Authority, in writing, within two months before the current holder of the heliport certificate ceases to operate the heliport for the heliport certificate to be transferred to the transferee.

7.4.2 If there are no changes in the original terms of the certificate, only the holder transfer shall be recorded and the certificate amended. If there are changes, the Authority shall evaluate the situation and communicate, in writing, to the transferee the actions to be taken. These actions may



go from a partial re-certification process or less, up to the application of the full certification process.

7.4.3 If the Authority does not consent to the transfer of a heliport certificate, it shall notify the transferee, in writing, of its reasons no later than 15 business days after making that decision.

7.5 Amendment of a heliport certificate

7.5.1 The Authority may amend a heliport certificate when:

- (a) there is a change in the ownership;
- (b) there is a change in the use;
- (c) there is a change in the boundaries of the heliport; or
- (d) the holder of the heliport certificate requests an amendment by requirement of the Authority.

7.6 Surrender of a heliport certificate

7.6.1 A heliport certificate holder must give the Authority not less than 60 days' written notice of the date on which the certificate is to be surrendered in order that suitable promulgation action can be taken.

7.6.2 The Authority shall cancel the heliport certificate after the notice period is closed.



This Page Intentionally Left Blank

**CHAPTER 8****HELIPORT OPERATIONS MANUAL****8.1 Requirement of the heliport operations manual**

- 8.1.1 To be a holder of a heliport certificate/licence, the applicant shall have a Heliport Operations Manual approved by the Authority, containing relevant information for the heliport maintenance and operation in accordance with its policies and procedures. This manual is called the Heliport Operations Manual – HOM.
- 8.1.2 An amendment to the HOM shall be approved by the Authority prior to becoming effective.
- 8.1.3 A compliance checklist shall accompany the application for approval. (See AC 8.1.3)

8.2 Preparation of the heliport operations manual (HOM)

(See Appendix 1)

8.2.1 The Heliport Operations Manual shall:

- (a) Be typewritten and printed in English;
- (b) Be in a format that is easy to revise and use;
- (c) Have a system for logging revisions;
- (d) Have the initial approval date and the list of effective pages duly signed to support the revision approvals.
- (e) Have a guarantee from the heliport operator, that the HOM and its revisions do not infringe any standards of this regulation.
- (f) Include all revisions and amendments required by the Authority, aimed at ensuring helicopter safety.
- (g) Be organised in a manner that will facilitate the preparation, review and acceptance/approval process by the Authority. It may be structured in one or multiple volumes, whichever is more convenient.
- (h) Some regulatory requirements, such as;
 - (1) SMS Manual;
 - (2) Heliport Emergency Plan;
 - (3) Rescue and Firefighting Manual,
 - (4) Training Manual;
 - (5) Preventive and Corrective Maintenance Plan; or
 - (6) Wildlife Hazard Management Plan



may be submitted separately but shall be referenced within the HOM and form part of the HOM.

- (7) The HOM shall comprise all policies and procedures including information and instructions necessary for the Accountable Manager to carry out their duties.

8.3 Contents of the heliport operations manual

- 8.3.1 The HOM required by this CAR shall contain all the relevant information concerning the heliport site, services, operating procedures, equipment, facilities, organisation and management including the SMS.
- 8.3.2 If a requirement is not included in the HOM because it is not applicable to the heliport, the reason shall be indicated in the manual.
- 8.3.3 As the accuracy of the operations manual information is critical to helicopter safety, information requiring engineering survey and assessment shall be gathered or verified by qualified technical persons.

Note: Refer to Appendix 1 for guidance on the content of the HOM.

8.4 Amendment and location of the heliport operations manual

- 8.4.1 A heliport operator shall:
 - (a) Ensure that the HOM is amended so that its instructions and information are current.
 - (b) Ensure that the administrative personnel, as well as the Operations, Maintenance and SMS personnel and any person or entity responsible for a manual, receive the approved revisions in a timely manner.
 - (c) Keep at least one complete and current copy of the HOM at each Operations, Maintenance and SMS Department.
 - (d) Provide the applicable parts or portions of the HOM, or a complete copy, to the heliport personnel in charge of its implementation.
 - (e) Keep master control of all existing manuals.
 - (f) Ensure any holder of the HOM, or any of its parts, is responsible for keeping this document up to date with the amendments provided by the heliport operator.

8.5 Heliport operations manual review

- 8.5.1 The Authority may review the HOM:
 - (a) At the heliport operator's request, who may require to include modifications to the conditions initially approved, related to the heliport site, services, operating procedures, equipment, facilities, organisation, heliport management or the SMS.
 - (b) If a revision is determined to be needed in the interest of safety.



- 8.5.2 An HOM revision request shall be submitted at least 30 business days prior to the date set for entry into force, unless the Authority approves a shorter period upon request of the applicant.
- 8.5.3 In case of revisions originated by the Authority, The heliport operator shall be notified of the reasons for revision and the pages with the proposed revisions shall be included. The heliport operator has seven business days to submit in writing his/her viewpoints and arguments on the revision. After evaluating the information, the Authority shall decide whether or not to adopt the revision. The revision shall be effective 30 business days after the heliport operator receives it.
- 8.5.4 If the Authority determines the presence of an emergency condition requiring immediate safety action that prevents the implementation of the procedures provided in paragraph 8.5.3, a revision shall be carried out and it shall be effective since the heliport operator receives it. The Authority shall briefly describe the emergency in the letter of formal amendment notice. Once the emergency is solved, the heliport operator may request the Authority a reevaluation of the elements causing the emergency and the revision required.

8.6 Approval of the heliport operations manual

- 8.6.1 For the purposes of HOM approval, or the volumes comprising it, the heliport operator shall submit two copies of each to the Authority.
- 8.6.2 The Authority shall approve the HOM or the volumes comprising it, and any revision provided that CAR requirements are met.
- 8.6.3 Once the HOM, or the volumes comprising it, are approved, the Authority shall return a copy to the heliport operator and keep a copy of each one in the heliport certification file.



This Page Intentionally Left Blank

**CHAPTER 9****OBLIGATIONS OF THE HELIPORT OPERATOR****9.1 General**

(See AC 9.1)

- 9.1.1 The heliport operator shall manage, operate and maintain the heliport in accordance with the policies and procedures set out in the HOM.
- 9.1.2 The heliport operator shall establish a preventive and corrective maintenance programme that meets the human factors principles to grant that pavement, fencing, drainage systems, buildings and other facilities are kept in such conditions that do not affect safety, regularity or efficiency of air navigation.

9.2 Records

9.2.1 The heliport operator shall establish a recording system including at least the following:

- (a) Heliport certification records;
- (b) Personnel training records;
- (c) Emergency training records;
- (d) Training records on fuel and hazardous material handling;
- (e) Audit and inspection records;
- (f) People accessing the movement area;
- (g) SMS records;
- (h) Wildlife strike records;
- (i) Records on heliport conditions;
- (j) Records on tool and equipment calibration; and
- (k) Incident/accident records.

9.2.2 The records in paragraph 9.2.1 above shall be kept permanently unless the specified regulation establishes a holding period.

9.3 Personnel competence and requirements

(See AC 4.3.2)

9.3.1 The heliport operator shall employ and maintain an adequate number of qualified and skilled personnel to perform all critical activities for heliport management, operations, maintenance, aviation security and safety.



- 9.3.2 The heliport operator shall submit to the Authority, for its approval, an initial and recurrent training programme in order to maintain the technical competence of personnel responsible for the management, operation and maintenance of the heliport, as provided in paragraph 9.3.1 above. The programme shall be included in the HOM.
- 9.3.3 The heliport operator shall submit to the Authority, for its approval, key operations and maintenance personnel of the heliport.
- 9.3.4 Any change in the approved management personnel shall be submitted to the Authority for approval.



CHAPTER 10

LICENSING PROCESS

10.1 Requirements for approval

(See AC 10.1)

- 10.1.1 A heliport operator shall apply to the Authority at least 90 days prior to proposed commencement of helicopter operations.
- 10.1.2 The heliport operator must satisfy the Authority that;
- (a) its organisation and management are suitable and properly matched to the scale and scope of the operation; and
 - (b) procedures for the supervision of operations have been defined
- 10.1.3 A heliport operator shall not provide any heliport related service otherwise than under, and in accordance with, the terms and conditions of a heliport licence from the Authority.
- 10.1.4 An applicant for a heliport licence, or variation of a heliport licence, shall allow the Authority to examine all safety aspects of the proposed service.
- 10.1.5 An applicant for a heliport licence, or revalidation of the heliport licence; shall
- (a) have his principal place of business and, if any, his registered office located in The Bahamas;
 - (b) satisfy the Authority that he is able to conduct safe services.
- 10.1.6 The heliport licence shall engage and/or employ the services of;
- (a) an Accountable Manager who has the authority within the organisation to ensure that each of the ATS units can be financed and properly organised, equipped and trained to meet the requirements of these regulations; and
 - (b) Sufficient personnel to manage, supervise, provide and support the heliport and any associated training or assessment processes agreed with and approved by the Authority
- 10.1.7 The persons listed in 10.1.6 shall be shall be responsible to the Accountable Manager and approved by the Authority. (See AC 10.1.7)
- 10.1.8 An applicant for a heliport licence shall establish a safety management system, which is;
- (a) in accordance with the framework elements contained CAR SMS; (See AC 10.1.8)
 - (b) commensurate with the size of the service provided and the complexity of its aviation products or services; and
 - (c) be made acceptable to the Authority as the State responsible for the heliport's licensing.

10.2 Grant of a heliport licence



(See AC 10.2)

10.2.1 The Authority shall issue the heliport licence provided:

- (a) The applicant has satisfactorily completed the technical licensing process;
- (b) The applicant and his staff have demonstrated the necessary competence and experience to operate and maintain the heliport safely;
- (c) The heliport operating manual (HOM) submitted by the applicant for approval contains all the relevant information corresponding to the heliport site, facilities, services, equipment, operating procedures, organisation and management as stated in this regulation;
- (d) The heliport facilities, services and equipment are in accordance with the relevant CAR;
- (e) The heliport operating procedures make satisfactory provision for the safety of helicopters; and
- (f) The applicant has implemented an acceptable SMS.

10.2.2 Any conditions or limitations stated on the heliport licence shall be complied with.

10.3 Duration of a heliport licence

10.3.1 A heliport licence issued under CAR AGA 2 shall remain in force from the date of issue until it is suspended, transferred or cancelled by the Authority or, alternatively, until the validity period has expired.

10.3.2 A heliport licence shall be valid for a maximum period of 5 years.

10.3.3 Any renewals of the heliport licence shall be subject to approval by the Authority.

10.3.4 The Authority may revoke a heliport licence if during the surveillance process the heliport operator does not demonstrate that it maintains the necessary competencies or if it incurs in recurring failures in the resolution of any non-conformities found.

10.4 Transfer of a heliport licence

10.4.1 The Authority may give its consent to and issue an instrument of transfer of a heliport licence to a transferee when:

- (a) The current holder of the heliport licence notifies the Authority, in writing, at least three months before ceasing to operate the heliport as of the date specified in the notice, including the name of the transferee or heliport operator.
- (b) The transferee applies to the Authority, in writing, within two months before the current holder of the heliport licence ceases to operate the heliport for the heliport licence to be transferred to the transferee.

10.4.2 If there are no changes in the original terms of the licence, only the holder transfer shall be recorded and the licence amended. If there are changes, the Authority shall evaluate the situation



and communicate, in writing, to the transferee the actions to be taken. These actions may go from a partial re-licensing process or less, up to the application of the full licensing process.

10.4.3 If the Authority does not consent to the transfer of a heliport licence, it shall notify the transferee, in writing, of its reasons no later than 15 business days after making that decision.

10.5 Amendment of a heliport licence

10.5.1 The Authority may amend a heliport licence when:

- (a) there is a change in the ownership;
- (b) there is a change in the use;
- (c) there is a change in the boundaries of the heliport; or
- (d) the holder of the heliport licence requests an amendment by requirement of the Authority.

10.6 Surrender of a heliport licence

10.6.1 A heliport licence holder must give the Authority not less than 60 days' written notice of the date on which the licence is to be surrendered in order that suitable promulgation action can be taken.

10.6.2 The Authority shall cancel the heliport licence after the notice period is closed.



This Page Intentionally Left Blank



APPENDIX 1

CONTENTS OF THE HELIPORT OPERATIONS MANUAL (HOM)

(See AC to Appendix 1)

The HOM shall include the following information applicable to the size, category and complexity of its operations shall be included. (See AC to Appendix 1)

Part 1: General

1.1 General Information

- (a) Purpose and scope of the HOM;
- (b) Legal requirement stating that the HOM and the heliport operator comply with all applicable regulations as prescribed in the provisions and conditions of the heliport certificate;
- (c) A statement that the HOM includes operating instructions to be met by relevant personnel;
- (d) A statement to indicate that the heliport shall at all times, when it is available for the take-off and landing of helicopters, be so available to all persons on equal terms and conditions;
- (e) The system for recording helicopter movement; and
- (f) The available aeronautical information system and procedures for its promulgation and/or notification to the Aeronautical Information Service (AIS);

1.2 Explanations and definitions of terms and words needed to use the HOM.

1.3 Amendment and review system

- (a) A statement of who is responsible for the issuance and disclosure of amendments and revisions.
- (b) A record of amendments and revisions with their corresponding entry and effective dates.
- (c) A statement that no handwritten amendments or revisions are allowed except in situations requiring an immediate amendment or revision in the interest of operational safety.
- (d) A list of effective pages.
- (e) A description of the distribution system of the HOM, amendments and revisions.

Part 2: Organisation

- 2.1 A heliport organisational chart showing the names and positions of management personnel.
- 2.2 Functions and responsibilities of management personnel.
- 2.3 Heliport committees, including Safety and Facilitation, Fauna, Emergency, and any other committee established by the heliport operator to ensure heliport safety and operation.

**Part 3: Particulars of the Heliport Site**

General information, including the following:

- (a) A plan of the heliport showing the main heliport facilities for the operation of the heliport including, particularly, the location of each wind direction indicator; lights, markings, signs, access to the heliport, perimeter roads, fuel storage, rescue and firefighting installations, ATC facilities and location or road-holding position for rescue and firefighting vehicles in case of emergency and an isolated parking position for a helicopter which is believed to be the subject of unlawful interference.
- (b) A plan of the heliport showing the heliport boundaries;
- (c) A plan showing the distance of the heliport from the nearest city, town or other populous area, and the location of any heliport facilities and equipment outside the boundaries of the heliport covering a diameter of at least 8 km ;
- (d) Particulars of the title (cadastral plan) of the heliport site. If the boundaries of the heliport are not defined in the document particulars of the title to, or interest in, the property on which the heliport is located and a plan showing the boundaries and position of the heliport.

Part 4: Particulars of the heliport required to be reported to the Aeronautical Information Service (AIS)**4.1 General information**

- (a) The name of the heliport;
- (b) The location of the heliport;
- (c) The geographical coordinates of the heliport reference point determined in terms of the World Geodetic System (WGS-84). The heliport reference point shall be located near the initial or planned geometric centre and shall be measured in degrees, minutes and seconds.
- (d) The heliport elevation and geoid undulation, with an accuracy rounded to the nearest one-half metre;
- (e) The heliport dimensions, including FATO, TLOF and TODAH.
- (f) The heliport reference temperature in degrees Celsius, which shall correspond to the monthly mean of the daily maximum temperatures for the hottest month of the year.
- (g) The details of the heliport beacon; and
- (h) The name of the heliport operator, address, telephone numbers and e-mail address at which The heliport operator may be contacted at all times.

4.2 Heliport dimensions and related information.

General information, including the following:

- (a) The heliport dimensions, including FATO, TLOF and TODAH.



- (b) Length, width and surface type of taxiways;
- (c) Apron surface type and helicopter stands;
- (d) Clearway length and ground profile;
- (e) Visual aids for approach procedures, marking and lighting of, taxiways, and aprons; other visual guidance and control aids on taxiways (including holding positions) and aprons, availability of standby power for lighting;
- (f) The location and designation of standard taxi routes;
- (g) The geographical coordinates of each FATO in degrees, minutes, seconds and hundredths of a second.
- (h) The geographical coordinates of each helicopter stand in degrees, minutes, seconds and hundredths of a second.
- (i) The geographical coordinates in degrees, minutes, seconds and hundredths of a second and the top elevation of significant obstacles in the approach and take-off areas in the vicinity of the heliport.

Note: This information may be best shown in the form of charts such as those required for the preparation of aeronautical information publications,

- (j) The pavement surface type and bearing strength in accordance with the standardised procedures of the Aircraft Classification Number – Pavement Classification Number (ACN-PCN) method, noting the following information:
 - (1) the Pavement Classification Number (PCN);
 - (2) pavement type for ACN-PCN determination;
 - (3) subgrade strength category;
 - (4) maximum allowable tyre pressure category or maximum allowable tire pressure value; and
 - (5) evaluation method.
- (k) One or more pre-flight altimeter check locations established on an apron and their average elevation rounded to the nearest metre or foot.
- (l) The following declared distances rounded to the nearest metre;
 - (1) take-off distance available (TODAH);
 - (2) rejected take-off distance available (RTODAH); and
 - (3) landing distance available (LDAH).
- (m) The condition of the movement area and the operational status of related facilities shall be monitored and reports on matters of operational significance or affecting helicopter performance given, particularly in respect of the following;



- (1) construction or maintenance work;
 - (2) rough or broken surfaces on a taxiway or an apron;
 - (3) water on a taxiway or an apron;
 - (4) chemicals or other contaminants on a taxiway or apron;
 - (5) other temporary hazards, including parked helicopters;
 - (6) failure or irregular operation of part or all of the visual aids; and
 - (7) failure of the normal or secondary power supply.
- (n) The disabled helicopter removal plan: the telephone/ telex/facsimile numbers and e-mail address of the heliport operator for the removal of a disabled aircraft on or adjacent to the movement area, information on the capability to remove a disabled helicopter, expressed in terms of the largest type of helicopter which the heliport is equipped to remove;
- (o) The Rescue and firefighting: the level of protection provided, expressed in terms of the category, which shall be in accordance with the type and amounts of extinguishing agents normally available at the heliport. Moreover, significant changes to the level of protection, level restoration and in terms of a new category, resulting from variations in availability of extinguishing agents, vehicles, personnel or any other requirement affecting the level of protection.
- (p) The following information concerning a visual approach slope indicator system installation shall be made available:
- (1) associated runway designation number;
 - (2) type of system and, for an AT-VASIS, PAPI or APAPI installation, the side of the runway on which the lights are installed, i.e. left or right, shall be given;
 - (3) where the axis of the system is not parallel to the runway centre line, the angle of displacement and the direction of displacement, i.e. left or right, shall be indicated;
 - (4) nominal approach slope angle(s). For a T-VASIS or an AT-VASIS this shall be angle Θ according to the formula in Figure 5-18 and for a PAPI and an APAPI this shall be angle $(B + C) \div 2$ and $(A + B) \div 2$, respectively as in Figure 5-20; and
 - (5) minimum eye height(s) over the threshold of the on-slope signal(s). For a T-VASIS or an AT-VASIS this shall be the lowest height at which only the wing bar(s) are visible; however, the additional heights at which the wing bar(s) plus one, two or three fly-down light units come into view may also be reported if such information would be of benefit to aircraft using the approach. For a PAPI this shall be the setting angle of the third unit from the runway minus 2', i.e. angle B minus 2', and for an APAPI this shall be the setting angle of the unit farther from the runway minus 2', i.e. angle A minus 2'.
- (q) Limitations, by helicopter type, in terms of resistance, runways, taxiways and turns.

Note: The accuracy of the information previously indicated is critical to aircraft safety. Information requiring engineering survey and assessment shall be gathered or verified by qualified technical persons. (See 8.3.3)



Part 5: Particulars of the Heliport Operating Procedures and Safety Measures.

5.1 Heliport reporting

Particulars of the procedures for reporting any changes to the heliport information set out in the AIP and procedures for requesting the issue of NOTAMs, including the following:

- (a) Arrangements for reporting any changes to the Authority and recording the reporting of changes during and outside the normal hours of heliport operations;
- (b) The names and roles of persons responsible for notifying the changes, and their telephone numbers during and outside the normal hours of heliport operations; and
- (c) The address and telephone numbers, as provided by the Authority, of the place where changes are to be reported to the AIS base stations.

5.2 Access to the heliport movement area

Particulars of the procedures that have been developed and are to be followed in coordination with the competent authorities for preventing unauthorised entry of persons, vehicles, equipment, animals or other things into the movement area, including the following:

- (a) The role of the heliport operator, the helicopter operator, heliport fixed-based operators, the heliport security entity, the Authority and other government departments, as applicable;
- (b) The names and roles of the personnel responsible for controlling access to the heliport, and the telephone numbers for contacting them during and after working hours;
- (c) Procedures to access the movement area, including: Issue and format of identification cards as well as the training plan, evaluation and consequences of non-compliance.
- (d) Responsibilities, procedures and means for communicating emerging problems of the pilot and the helicopter operator.

5.3 Heliport Emergency Plan

Particulars of the Heliport Emergency Plan, including the following:

- (a) Plans for dealing with emergencies occurring at the heliport or in its vicinity, including the malfunction of aircraft in flight or on the ground; structural fires, sabotage, including bomb threats (aircraft or structure); unlawful seizure of aircraft or facilities; and accidents or incidents on the airport covering “during the emergency” and “after the emergency” considerations;
- (b) The heliport emergency plan shall also include;
 - (1) arrangements for dealing with the accidental spillage of hazardous materials; and
 - (2) all aspects of the rescue and firefighting service.
- (c) Details of tests for heliport facilities and equipment to be used in emergencies, including the frequency of those tests; it shall not exceed two years.



- (d) Details of exercises to test emergency plans, including the frequency of those exercises; it shall not exceed two years.
- (e) A list of organisations, agencies and persons of authority, both on and off airport, for site roles; their telephone and facsimile numbers, e-mail and SITA addresses and the radio frequencies of their offices as well as any other communication system;
- (f) The establishment of a heliport emergency planning committee or similar agreement to organise training and other preparations for dealing with emergencies; and
- (g) The appointment of an on-scene commander to supervise the overall emergency operations.

5.4 Rescue and Firefighting Service

Facilities, equipment, personnel and procedures data to meet the rescue and firefighting requirements; including the names and roles of the persons responsible for dealing with the rescue and firefighting services at the heliport, training, exercises and response time demonstration.

Note: This subject shall also be covered in appropriate detail in the heliport emergency plan.

5.5 Inspection of the heliport movement area and obstacle limitation surface by the heliport operator

Particulars of the procedures for the inspection of the heliport movement area and obstacle limitation surfaces, including the following:

- (a) Arrangements for carrying out inspections, water-depth measurements on runways and taxiways, during and outside the normal hours of heliport operations;
- (b) Arrangements and means of communicating with air traffic control during an inspection;
- (c) Arrangements for keeping an inspection logbook, and the location of the logbook;
- (d) Details of inspection intervals and times;
- (e) Inspection guides and checklists;
- (f) Arrangements for recording and reporting the results of inspections and for taking prompt follow-up actions to ensure correction of unsafe conditions; and
- (g) The names and roles of persons responsible for carrying out inspections, and their telephone numbers during and after working hours.

5.6 Visual aids and heliport electrical systems

Particulars of the procedures for the inspection and maintenance of aeronautical lights (including obstacle lighting), signs, markers and heliport electrical systems, including the following:

- (a) Arrangements for carrying out inspections during and outside the normal hours of heliport operation, and the checklist for such inspections;
- (b) Arrangements for recording the result of inspections and for taking follow-up action to correct deficiencies;



- (c) Arrangements for carrying out routine maintenance and emergency maintenance;
- (d) Arrangements for secondary power supplies, if any, and, if applicable, the particulars or any other method of dealing with partial or total system failure; and
- (e) The names and roles of the persons responsible for the inspection and maintenance of the lighting, and the telephone numbers for contacting those persons during and after working hours.
- (f) Monthly verification of PAPI/VASI light angles and photo cell operation, by the responsible unit.

5.7 Maintenance of the movement area

Particulars of the facilities and procedures for the maintenance of the movement area, including;

- (a) Arrangements for maintaining the paved areas;
- (b) Arrangements for maintaining the unpaved runways and taxiways;
- (c) Arrangements for maintaining the runway and taxiway strips; and
- (d) Arrangements for the maintenance of heliport drainage.

5.8 Heliport works – Safety

Particulars of the procedures for planning and carrying out construction and maintenance work safely (including work that may have to be carried out at short notice) on or in the vicinity of the movement area which may extend above an obstacle limitation surface, including the following:

- (a) Arrangements for communicating with air traffic control during the progress of such work;
- (b) The names, telephone numbers and role of persons or organisations responsible for planning and carrying out the work, and arrangements for contacting those persons and organisations at all times;
- (c) The names, telephone numbers, during and after working hours, of the heliport fixed-base operators, ground handling agents and aircraft operators who are to be notified of the work;
- (d) A distribution list for work plans, if required; and
- (e) Arrangements, procedures and recovery time of major damage to the runway pavement.

5.9 Apron management

Particulars of the apron management procedures, including the following:

- (a) Arrangements between air traffic control and the apron management unit;
- (b) Arrangements for allocating helicopter parking positions;
- (c) Arrangements for initiating engine start;
- (d) Marshalling service; and



- (e) Leader (van) service.
- (f) Arrangements and procedures on movement/non movement areas, to determine when the control is to be taken by ATS.

5.10 Apron safety management.

Procedures to ensure apron safety, including:

- (a) Protection from helicopter downwash;
- (b) Enforcement of safety precautions during aircraft refuelling operations;
- (c) Apron sweeping;
- (d) Apron cleaning;
- (e) Arrangements for reporting incidents and accidents of an apron; and
- (f) Arrangements for auditing the safety compliance of all personnel working on the apron.

5.11 Airside vehicle control

Particulars of the procedures for the control of surface vehicles operating on or in the vicinity of the movement area, including:

- (a) Details of the applicable traffic rules (including speed limits and the means of enforcing the rules);
- (b) The method of issuing driving permits for operating vehicles in the movement area;
- (c) Identification (signalling) procedures and safety equipment; and
- (d) Compliance with the procedures for the total annual vehicle technical inspection and when in doubt, with the operating conditions of vehicles.

5.12 Wildlife hazard management

Particulars of the procedures to deal with the danger posed to helicopter operations by the presence of bird or other animals in the heliport flight pattern or movement area, including the following:

- (a) Arrangements for assessing wildlife hazards;
- (b) Arrangements for implementing wildlife control programmes; and
- (c) The names and roles of the persons responsible for dealing with wildlife hazards, and their telephone numbers during and after working hours.

5.13 Obstacle control

Particulars setting out the procedures for:

- (a) Monitoring the obstacle limitation surfaces and Type A Chart for obstacles in the take-off surface;



- (b) Controlling obstacles within the authority of the heliport operator;
- (c) Monitoring the height of buildings or structures within the boundaries of the obstacle limitation surfaces;
- (d) Controlling new developments in the vicinity of the heliport;
- (e) Notifying the Authority of the nature and the location of obstacles and any subsequent addition or removal of obstacles for action as necessary, including amendment of the AIS publication; and
- (f) Evaluating and updating the obstacle letter.

5.14 Removal of disabled helicopters

Particular of the procedures for removing a disabled helicopter on or adjacent to the movement area, including the following:

- (a) The roles of the heliport operator and the holder of the helicopter certificate of registration;
- (b) Arrangements for notifying the holder of the certificate of registration;
- (c) Arrangements for liaising with the air traffic control unit;
- (d) Arrangements for obtaining equipment and personnel to remove the disabled helicopter; and
- (e) The names, role and telephone numbers of persons responsible for arranging for the removal of disabled helicopter.

5.15 Handling of hazardous materials

Particulars of the procedures for the safe handling and storage of hazardous materials on the heliport, including the following:

- (a) arrangements for special areas on the heliport to be set up for the storage of inflammable liquids (including aviation fuels) and any other hazardous materials; and
- (b) the method to be followed for the delivery, storage, dispensing and handling of hazardous materials, including areas for temporary storage of containers and packing with spills.

Note: Hazardous materials include inflammable liquids and solids, explosives, solvents, corrosive liquids, compressed gases and magnetised or radioactive materials. Arrangements for dealing with the accidental spillage of hazardous materials shall be included in the heliport emergency plan.

5.16 Reduced-visibility operations

Particulars of procedures to be introduced for low-visibility operations, including the measurement and reporting of runway visual range as and when required, and the names and telephone numbers, during and after working hours, of the persons responsible for measuring the runway visual range.



5.17 Protection of sites for radar and navigational aids

Particulars of the procedures for the protection of sites for radar and radio navigational aids located on the heliport to ensure that their performance will not be degraded, including the following;

- (a) arrangements for the control of activities in the vicinity of radar and navigational aids installations;
- (b) arrangements for ground maintenance in the vicinity of these installations; and
- (c) arrangements for the supply and installation of signs, warnings of hazardous microwave radiation.

Note 1: In writing the procedures for each category, clear and precise information shall be included on:

- *When, or in what circumstances, an operating procedure is to be activated;*
- *how an operating procedure is to be activated;*
- *actions to be taken;*
- *the persons who are to carry out the actions; and*
- *the equipment necessary for carrying out the actions, and access to such equipment.*

Note 2: If any of the procedures specified above are not relevant or applicable, the reason shall be given.

Part 6: Heliport Safety Management System

- (a) General description of the SMS established for ensuring compliance with all safety requirements provided in CAR SMS;
- (b) The safety policy, insofar as applicable, on the safety management process and its relation to the operational and maintenance process;
- (c) the structure or organisation of the SMS, including staffing and the assignment of individual and group responsibilities for safety issues;
- (d) SMS strategy and planning, such as setting safety performance targets, allocating priorities for implementing safety initiatives and providing a framework for controlling the risks to as low a level as is reasonably practicable keeping always in view the requirements of CAR's, as well as the applicable local regulations, standards, rules or technical guides;
- (e) SMS implementation, including facilities, methods and procedures for the effective communication of safety messages and the enforcement of safety requirements;
- (f) a system for the implementation of, and action on, critical safety areas which require a higher level of safety management integrity (safety measures programme);
- (g) measures for safety promotion and accident prevention and a system for risk control involving analysis and handling of accidents, incidents, complaints, defects, faults, discrepancies and failures, and continuing safety monitoring;



- (h) A system of voluntary notification of events, events or hazards that affect or may affect aeronautical safety
- (i) the internal safety audit and review system detailing the systems and programmes for quality control of safety;
- (j) the system for documenting all safety-related heliport facilities as well as heliport operational and maintenance records, including information on the design and construction of helicopter pavements and heliport lighting. The system shall enable easy retrieval of records including charts;
- (k) staff training and competency, including the review and evaluation of the adequacy of training provided to staff on safety-related duties and of the certification system for testing their competency; and
- (l) The incorporation and enforcement of safety-related clauses in the contracts for construction work at the heliport.



This Page Intentionally Left Blank



SECTION 2

ADVISORY CIRCULARS (AC)

1. General

This section 2 contains Advisory Circulars (AC), which is additional text related to the CAR requirements to clarify and provide guidance for its application. It contains explanations, interpretations and/or acceptable means of compliance.

Where a particular paragraph does not have AC, it means that such paragraph does not require it.

2. Presentation

The numbering proceeded by the acronym AC indicates the paragraph number of CAR AGA 2 they refer to.



This Page Intentionally Left Blank



CHAPTER 1

GENERAL

AC 1.6.4 Service Level Agreements

(See AGA 2 para 1.6.4)

This AC is an alternative means of compliance on how Service Level Agreements may be established.

Memorandum of Understanding between the Helicopter operator ----- and -----.

1) **FRONT PAGE:**

“Agreement between: Corporate Name or name of the Helicopter Operator and Corporate Name or name of the other signatory.”

2) **PREAMBLE:**

The aforementioned entities have agreed that is mutually beneficial to establish a formal understanding for the efficient and safe development of helicopter activities.

3) **SUBJECT:**

(Indicate subject to be agreed)

4) **OBJECTIVES:**

“Depending on the topic, briefly describe the objectives”

5) **RESPONSIBILITIES:**

Each of the signing parties of this agreement shall be responsible that personnel under their authority comply with the provisions set forth herein. The initial and recurrent training of personnel involved shall be under the responsibility of the signing parties.

6) **PROCEDURES OF THE HELICOPTER OPERATOR:**

- a. Procedures of the Helicopter Operator
- b. Procedures of the other signing party

7) **EFFECTIVE DATE:**

This Service Level Agreement shall enter into force on the date it is signed and shall remain effective until either party notifies the other in writing of the intention to terminate the agreement. In that case, the termination shall occur two (2) months after receiving the notification.

8) **MODIFICATION:**

This agreement may be amended by mutual consent under a written communication exchange between the two parties.

9) **PLACE AND DATE OF SIGNING**

Signed at _____ on _____ of _____.

10) **SIGNATURE:**

Helicopter Operator

Other signatory

**AC 1.8 Aeronautical Studies**

(See AGA 2 para 1.8)

PURPOSE

An aeronautical study is conducted to evaluate the consequences of deviations with respect to the heliport standards established according to the requirements of CAR AGA 2 Chapter 3 to present alternative means of ensuring helicopter operations safety, evaluate the effectiveness of each alternative and recommend procedures to compensate the deviations.

APPLICABILITY

An aeronautical study may be conducted when the aerodrome standards may not be complied with, as a result of development or expansion. Such study is often conducted during the planning process of a new heliport or during the licensing of an existing one.

Note: Aeronautical studies may not be conducted in case of deviations with respect to the standards if there are reasonably practicable solutions.

DEFINITION

An aeronautical study is an investigation of an aviation problem aimed at identifying possible solutions and selecting the most acceptable one so that it does not affect flight safety.

TECHNICAL ANALYSIS

The technical analysis shall provide justification for a deviation on the basis that an equivalent level of safety may be achieved by other means. It is generally applied in situations where the cost of correcting a problem that infringes standard results excessive, but where the unsafe effects of the problem may be overcome by any procedural means offering practical and reasonable solutions.

In technical analysis, inspectors shall apply their field experience and expertise. They may also consult other specialists in relevant areas. When considering alternative procedures in the deviation approval process, it is essential to take into account the safety purpose of the heliport regulations and the applicable standards so that the purpose of the regulations is maintained.

DEVIATION ACCEPTANCE

In some cases, the only reasonable means of providing an equivalent level of safety is to adopt adequate procedures and demand, as a condition for licensing, that caution notices be published in appropriate AIS publications.

The decision of demanding caution notices shall depend mainly on two considerations:

- a) The pilots' need of being aware of the possible dangerous conditions; and
- b) The responsibility of the Authority to publish deviations with respect to the standards, which otherwise are assumed to be met under the aerodrome licensing.

STRUCTURE OF THE AERONAUTICAL STUDY

The minimum contents required in an aeronautical study shall be the following:

Section 1. General

- a) Title page of the study
- b) Name and signature of the person in charge of the study
- c) General index
- d) Objective
- e) Scope



Section 2. Risk analysis

- a) Description of the deviation by indicating the difference with respect to the standards specified in the CAR AGA 2, Chapter 3.

Section 3. Identification of unwanted events

a) Estimate the probability of an incident or an accident related to deviations similar to those under analysis. The probability shall be classified as:	b) Description of the consequences magnitude of incidents or accidents occurrence. The magnitude of the consequences is classified as:
•Frequent	•Catastrophic
•Occasional	•Dangerous
•Remote	•Major
•Unlikely	•Minor
•Extremely unlikely	•Insignificant

Section 4. Mitigation measures

- a) Description of the mitigation measures applied to eliminate or reduce as much as possible the detected risks.

Section 5. Results

- a) Description of the results derived from the implementation of mitigation measures, including the necessary documentation to support such results.
- b) Comparison of results obtained with respect to standards specified in CAR AGA 2, Chapter 3.
- c) Conclusions.

Section 6. Annexes

All documents (procedures, analysis, reports, records, photographs, maps, tables, graphics, etc.) and any supporting information needed for the aeronautical study shall be included.

AC 1.11 Requirement for a Heliport Certificate

(See AGA 2, para 1.11)

When a Certificate is granted to a heliport, for helicopter operators and other organisations operating on it, it means that at the time of certification the heliport it complied with the standards relating to the facilities and their operation and the operator has in agreement with the Authority, the ability to continue to meet those specifications during the validity of the licence.

The certification process also establishes the benchmark for continuous monitoring of compliance with specifications.

It is necessary to provide to the aeronautical information services, relevant information on the status of certification of heliport to be promulgated in the Aeronautical Information Publication (AIP). See CAR AIS.

AC 1.13 Requirement for a Heliport Licence

(See AGA 2, para 1.13)

When a Licence is granted to a heliport, for helicopter operators and other organisations operating on it, it means that at the time of licensing the heliport it complied with the standards relating to the facilities and their operation and the operator has in agreement with the Authority, the ability to continue to meet those specifications during the validity of the licence.

The licensing process also establishes the benchmark for continuous monitoring of compliance with specifications.

It is necessary to provide to the aeronautical information services, relevant information on the status of licensing of heliport to be promulgated in the Aeronautical Information Publication (AIP). See CAR AIS.



This Page Intentionally Left Blank



CHAPTER 7

CERTIFICATION PROCESS

AC 7.1 Certification Process

(See AGA 2 para 7.1)

To obtain a heliport certificate or licence, the applicant must undergo a certification/licensing process, which is formally recorded in a heliport certification file by the Authority. This process consists of the following stages:

Stage 1 - Pre-application

This is the process where the applicant expresses an interest in obtaining a heliport certificate obtains the information required relating to the granting of a heliport certificate. During this stage, the first meeting between the applicant and the Authority takes place, where there is an information exchange on service and guidance in regards to the regulations, standards, procedures, responsibilities and privileges of the service that the applicant intends to provide, and the technical documentation to be submitted.

Stage 2 - Formal Application

The applicant shall submit the a formal application to the Authority attaching the schedule of events for the certification process, the Heliport Operations Manual (HOM) required by these regulations, the Heliport Security Programme required by CAR SEC and the SMS of the heliport required by CAR SMS.

Stage 3 – Evaluation

The Authority conducts a thorough review of the documentation submitted and informs the applicant of any discrepancies found; otherwise, provisional approval/acceptance is issued.

Stage 4 - Technical Evaluation

The applicant is subjected to a technical demonstration and evaluation to determine compliance with the facilities with respect to signals, lighting, markings, pavements, obstacles, rescue and firefighting services, equipment, personnel, procedures, SMS, apron management, wildlife strike hazard and training.

Stage 5 – Certification/Licensing

Once stages 1 to 4 have been successfully completed, the Authority shall grant the heliport certificate/licence with any conditions established for promulgation in the Bahamas AIP.

AC 7.1.7 Key Personnel

(See AGA 2 para 7.1.7)

The heliport operator must submit to the Authority, for its approval, key operations and maintenance personnel of the heliport-

a) Operations:

- 1) Higher education in engineering or heliport administration, or an aviation technician license or any other career related to heliport operations.
- 2) A minimum of five years of experience in heliport management.

b) Maintenance:

- 1) Higher education in civil, mechanical, or electric engineering, construction or architecture or a qualified technician with proven experience subjected to Authority approval.
- 2) Heliport specialised courses.
- 3) Three years of proven experience in positions related to supervision and inspection of the movement area or two years subject to a training plan proposed by the heliport operator and approved by the Authority.



- c) Safety Management
 - 1) Qualified technician with proven knowledge and experience in SMS.
 - 2) A minimum of three years of proven experience in quality systems or heliport SMS.

Any change in the authorised key personnel payroll, must be submitted to the Authority for approval.

AC 7.2 Safety management systems

(See AGA 2 Para 7.2)

The intent of a safety management system is to have in place an organised and orderly approach in the management of heliport safety by the heliport operator. CAR SMS Safety Management Systems contains the safety management provisions applicable to certified/licensed heliports.



CHAPTER 8

HELIPORT OPERATIONS MANUAL (HOM)

AC to Appendix 1 Preparation of the Heliport Operations Manual (HOM)

(See AGA 2 Appendix 1)

One of the most important reasons for the existence of the HOM is that it serves as an extension of the regulations. CAR AGA 2 provides information in broad terms to cover all heliports and it may not appear in a specific level for each heliport. The HOM becomes a bridge between the requirements and the individual application for a heliport taking into account size, activities and configuration.

In the development of the HOM, two fundamental principles shall be observed:

- a) **Be comprehensive.** It shall include all requirements applicable to the heliport, so that personnel operating in the heliport have the necessary information to comply with the regulations. Even quotes or references to regulations, may be included.
- b) **Be moderate.** It shall be created with the level of detail necessary to show how to achieve compliance with regulations in the heliport. Excessive details that may restrict the flexibility to meet unforeseen circumstances or the creation of commitments not stated in regulations in terms of responsibility, authority and procedures shall be avoided.

There are two relevant levels of approval in the regulations: the approval or compliance statement by the heliport operator or the applicant of a heliport certificate/licence before submitting it to the Authority, and Authority's approval.

The highest authority within the structure of the Heliport Operator, on behalf of the company it represents, shall establish a statement or approval that the manual complies and that the operator shall meet all applicable rules as well as the provisions and conditions of the heliport certificate/licence in a note or letter. The note or representation letter shall identify the heliport, the person signing the document and the date. This approval may be issued in the front page or the first page of the manual.

Once the HOM is approved, it becomes an authorised document. Therefore, the Authority shall issue an initial approval note of the Heliport Operations Manual (HOM) and also indicate its approval with the full name, date and signature of the designated inspector, at the end of each sheet of the effective pages of the manual.

To comply with regulatory requirements, the heliport operator shall foresee that the policies and procedures of the HOM respond to these questions. A realistic and objective HOM is the one that provides guidelines and instructions necessary for another person to develop its activities while the heliport operator is absent. When the person is reading the instructions, these shall indicate who is performing the tasks, what they consist of, how they shall be conducted and the schedules or periods to perform them.

Two aspects require debate. There is a person who normally operates far away under a relative autonomy, not beyond the authority, but with some physical or functional distance. This is called *independent* person for convenience. The key element is that this person can make decisions to deal with abrupt changes in situations without direct supervision, even if the heliport operator is located anywhere in the heliport. The other person is the *substitute*, who intervenes and performs certain tasks to meet the regulations when the usual chain of authority and responsibility has been temporarily interrupted. This person is essentially an aid and may or may not be completely familiarised with the normal routine. The HOM shall provide enough guidance to perform functions as well as the course and instructions to request support when problems arise.

As it was previously indicated, this person is not entirely independent on authority or action, but certain relevant actions may be carried out without the participation of the heliport operator or the normal procedure of application and approval. Therefore, the heliport operator must be sure that the person knows what is required from the regulation point of view, how to apply his/her knowledge in adverse situations as well as to conduct routine work, which may be accomplished by firm and clear instructions in the HOM. Rescue and firefighting services represent a good example. In the rescue and firefighting station, events requiring immediate attention may arise and they may have consequences somewhere else or for other people. For example, if a piece of equipment is not working, administrative action must be taken to restrict air operations or, at least, notify the heliport operators. In case of an emergency, it is necessary to decide whether to activate the emergency plan or just part of it. Do the rescue and firefighting personnel know how to make these decisions? Do they have clear and concise information for the correct approach? Of course, it must be clear who the person in charge of giving instructions is.



It is important to keep in mind who may take action if the heliport operator or the nominated person is absent. Taking daily inspections as an example, if a person knows the heliport operations, but he/she does not know the specific regulations, it may be unnecessary to give instructions from scratch. However, the person usually does not perform those functions. Therefore, the HOM shall be specific enough on critical aspects of the operation, so that the heliport takes its normal course.

Nevertheless, if the heliport operator is not in the facilities, there shall be another person to perform the tasks instead of the appointed person. If the person in charge of checking the lighting system is off, the substitute must know how to check the system and where the switches are. In other words, an instruction in the HOM stating, "The lighting system must be checked to meet the requirements" is not enough.

The instructions in the HOM shall detail what tasks must be conducted and how they shall be carried out by people responsible for its compliance. Unless every person designated for a task is completely familiar with the regulation requirements, the HOM must be structured so that it provides the appropriate guidance. For example, it may be confusing if the HOM states, "*The security areas must be kept according to the regulations*". Unless the personnel knows the regulations, a better description shall provide details identifying the physical limits, the revision periods and how to keep the surfaces of the safety and security areas.

The best instructions will not produce satisfactory results if they do not indicate when they shall be put into practice. Is the instruction "*The personnel shall conduct refuelling inspections every day*" specific enough? Can a person take action if the HOM indicates "*When the weather conditions allow it*"? Closely related questions like who, what, how and when may arise from these indications and the HOM instructions shall provide enough information to answer them.

AC 8.1.3 Heliport Operations Manual (HOM) Compliance Letter
(See AGA 2 para 8.1.3)

The Heliport operator shows that it fully complies with the standards established in these regulations through a compliance letter. There shall be a policy or procedure for each standard in the Manual system taking into account the complexity and size of the operations.



CHAPTER 9

OBLIGATIONS OF THE HELIPORT OPERATOR

AC 9.1 General

(See AGA 2 para 9.1)

- a) Preventive maintenance is programmed maintenance work done in order to prevent a failure or degradation of facilities.
- b) "Facilities" are intended to include such items as pavements, visual aids, fencing, drainage systems, electrical systems and buildings.
- c) Guidance material on Human Factors principles can be found in the Human Factors Training Manual (Doc 9683) and in the Airport Services Manual (Doc 9137), Part 8.

AC 9.3.2 Personnel competence

(See AGA 2 para 9.3.2)

Personnel responsible of the administration, operations and maintenance of the heliport shall be trained to a level according to the tasks to be performed; therefore, the programme contents of the initial and recurring training of the heliport operator shall be based on the policy and procedures stated and approved by the Authority in the Heliport Operations Manual (HOM). These shall include at least the following:

a) Initial training

- (1) Training in airport operations.
- (2) Training in standards and security of fuel storage and handling in the heliport.
- (3) Training in the inspection system including familiarisation with the heliport, emergency plan, NOTAMs, vehicle operation and discrepancy report system.
- (4) Rescue and firefighting training
- (5) Training in regulations, standards and HOM
- (6) Introduction to the investigation of aviation accidents and incidents
- (7) Maintenance of visual and electronic aids and pavements
- (8) Human factors in civil aviation (ICAO Doc. 9683)
- (9) Dangerous goods training, based on CAR DG
- (10) Bird and other animals control (ICAO IBIS Doc 9332)
- (11) Operational Security Management System
- (12) Quality System

b) Recurring training

- 1) Every two years, (a) (2), (4), (5) and (9) courses shall be given to the appropriate personnel.
- 2) Every year, the training indicated in (a) (3) shall be conducted for the inspection personnel.
- 3) Instruction not indicated in the previous paragraphs shall be given in periods not exceeding 5 years.

c) Training files

Training files of the Heliport operator shall indicate the amount of formal training, on the job training (OJT) and the experience that each employee has accumulated over the years.



d) Planning and design

The planning and design stage establishes the basis to define the instruction specifications such as the intermediate and final objectives, expected results, group to be trained, training course contents and specifications, which allow the further development of a training programme.

This stage includes:

- planning and design actions that require to be executed to fill the gap between the current competence and the required competence, and
- definition of the criteria to establish the job performance standards and the performance requirements as well as the evaluation criteria of the instruction process and the subsequent objectives for each course.

The training programme shall be created taking into account the human factors for its implementation. Moreover, it shall consider the depth of each course or subject depending on the responsibilities of the personnel to be trained.

Usually, human resources management is in charge of the administration of resources needed for the correct compliance with the different instruction methods, required teaching materials, activity design, hiring of external instructors, training for internal instructors and their availability, transport to contracted training centres/factories or providers of the different products and services.

However, the highest authority within the heliport operator is responsible for the approval of any method used for instruction (regardless of whether the instruction is contracted from a third party), as well as for the contents of the training programmes. This may require that contents and evaluation systems of the different courses are audited.

This audit or revision of the training programme by the operator shall be conducted in order to detect non-compliance problems, and eventually, corrective actions.

Data collection shall be performed continuously to provide the basis for the instructional process validation and offer the necessary recommendations to improve it.

AC 9.9.2 Rescue and firefighting: Equipment and extinguishing agents

(See AGA 2 para 9.9.2)

The amounts of water specified for foam production are predicated on an application rate of 8.2 L/min/m² for a foam meeting performance level A, 5.5 L/min/m² for a foam meeting performance level B and 3.75 L/min/m² for a foam meeting performance level C.

When any other complementary agent is used, the substitution ratios need to be checked.

Descriptions of the agents may be found in the Airport Services Manual (Doc 9137), Part 1.

Information on the required physical properties and fire extinguishing performance criteria needed for a foam to achieve an acceptable performance level A, B or C rating is given in the Airport Services Manual (Doc 9137), Part 1.

In addition to the provisions the *Airport Services Manual* (Doc 9137), Part I, on rescue and firefighting equipment and extinguishing agents, this AC states some acceptable standards from National Fire Protection Association (NFPA) and the Federal Aviation Administration (FAA), both from the United States of America.

NFPA 412 Standard for Evaluating Aircraft Rescue and Fire Foam Equipment

NFPA 414 Aircraft Rescue and Firefighting Vehicles

FAA-AC150/521B0-14 (Airport Fire and Rescue Personal Protective Clothing)

See the Airport Services Manual (Doc 9137), Part 1 for guidance on the conduct of a risk analysis to determine the quantities of reserve extinguishing agents.



Guidance regarding to the rescue and firefighting equipment to be provided at the heliports is provided in Airport Services Manual (Doc 9137, Part 1)

Guidance on the determination of quantities of water and discharge rates based on the largest theoretical aeroplane in a given category is available in Chapter 2 of the Airport Services Manual (Doc 9137), Part 1.

AC 9.9.4 Rescue and firefighting: Response time

(See AGA 2 para 9.9.4)

- a) Response time is considered to be the time between the initial call to the rescue and firefighting service, and the time when the first responding vehicle(s) is (are) in position to apply foam at a rate of at least 50 per cent of the discharge rate specified in Table 4.
- b) Optimum visibility and surface conditions are defined as daytime, good visibility, no precipitation with normal response route free of surface contamination, e.g. water, fog, ash, sand, mud.

Additional guidance is available in the Airport Services Manual (Doc 9137), Part 1.

In addition to the provisions of the *Airport Services Manual* (Doc 9137), Part I, on rescue and firefighting training, this AC states some acceptable standards for the compliance of the 21B.319 (j) norm, originally from National Fire Protection Association (NFPA) and the Federal Aviation Administration (FAA), both from the United States of America.

NFPA 402 Guide for Aircraft Rescue and Firefighting Operations

NFPA 405 Proficiency Training of Aircraft Rescue Firefighting Personnel

FAA-AC 150/521B0-7 Aircraft Rescue and Fire Communications

FAA-AC 150/521B0-17 Programme for Training of Aircraft Rescue and Firefighting Personnel

FAA-AC 150/5220-17 Design Standards for an Aircraft Rescue and Firefighting Training Facility

Fires associated with fuel discharged under very high pressure from a ruptured fuel tank are known as “pressure-fed fuel fires”.

Guidance material to design training programmes on human performance and team coordination can be found in the Human Factors Training Manual (Doc 9683).

Guidance on the use of a task resource analysis can be found in the Airport Services Manual (Doc 9137), Part 1.

Heliport service roads may serve as emergency access roads when they are suitably located and constructed. Special firefighting equipment need not be provided for water areas; this does not prevent the provision of such equipment if it would be of practical use, such as when the areas concerned include reefs or islands.

The objective is to plan and deploy the necessary life-saving flotation equipment as expeditiously as possible in a number commensurate with the largest aeroplane normally using the heliport.

Additional guidance is available in Chapter 13 of the Airport Services Manual (Doc 9137), Part 1.

AC 9.9.9 Rescue and firefighting: operational requirements

(See AGA 2 para 9.9.9)

Besides of the ICAO provisions in the *Airport Services Manual* (Doc 9137), Part 1, on the location and specifications on the rescue and firefighting station, this AC states some acceptable standards originally from the National Fire Protection Association (NFPA) and the Federal Aviation Administration (FAA), both from the United States of America.

NFPA 403 Aircraft Rescue and Firefighting Services at Airports

FAA-AC 150/521B0-15 Airport Rescue and Firefighting Station Building Design



AC 9.12 Heliport emergency planning
(See AGA 2 para 9.12)

Heliport emergency planning is the process of preparing a heliport to cope with an emergency occurring at the heliport or in its vicinity. The objective of heliport emergency planning is to minimize the effects of an emergency, particularly in respect of saving lives and maintaining aircraft operations. The heliport emergency plan sets forth the procedures for coordinating the response of different heliport agencies (or services) and of those agencies in the surrounding community that could be of assistance in responding to the emergency.

Guidance material and standard procedures for the development of the heliport emergency plan are given in the ICAO *Airport Services Manual* (Doc 9137), part 7 and the advisory circular joint FAA AE 150/5200–31 A.

Examples of emergencies are: aircraft emergencies, sabotage including bomb threats, unlawfully seized aircraft, dangerous goods occurrences, building fires, natural disaster and public health emergencies.

Examples of public health emergencies are increased risk of travellers or cargo spreading a serious communicable disease internationally through air transport and severe outbreak of a communicable disease potentially affecting a large proportion of heliport staff.

Guidance material on Human Factors principles can be found in the Human Factors Training Manual (Doc 9683).

The plan includes all participating agencies and associated equipment.

The purpose of a full-scale exercise is to ensure the adequacy of the plan to cope with different types of emergencies. The purpose of a partial exercise is to ensure the adequacy of the response to individual participating agencies and components of the plan, such as the communications system. The purpose of modular tests is to enable concentrated effort on specific components of established emergency plans.

Guidance material on airport emergency planning is available in the Airport Services Manual (Doc 9137), Part 7.

AC 9.13 Handling and storage of hazardous materials
(See AGA 2 para 9.13)

Besides of the ICAO provisions in the *Airport Services Manual* (Doc 9137), Part 1, Chapter 16, this AC states some acceptable standards for the compliance of standards on the facilities design, equipment and storage systems, fuel handling and dispensing, originally from the National Fire Protection Association (NFPA) and the Federal Aviation Administration (FAA), both from the United States of America.

- NFPA 10 Standards for Portable Fire Extinguishers
- NFPA 30 Flammable and Combustible Liquid Code
- NFPA 385 Tank Vehicles for Flammable and Combustible Liquids
- NFPA 408 Aircraft Hand Portable Fire Extinguishers
- NFPA 407 Aircraft Fuel Servicing
- NFPA 415 Standard on Airport Terminal Buildings, Fuelling Ramp Drainage, and Loading Walkways
- FAA-150/5230-4 Aircraft Fuel Storage, Handling and Dispensing on Airports

AC 9.14 Guidance on a heliport safety management system
(See AGA 2 para 9.14)

The intent of a safety management system is to have in place an organised and orderly approach in the management of heliport safety by the heliport operator. CAR SMS - Safety Management Systems contains the safety management provisions applicable to certified/licensed heliports. Guidance on a harmonized safety management system is given in the Safety Management Manual (SMM) (Doc 9859) and in the Manual on Licensing of Aerodromes (Doc 9774). Procedures on the management of change, conduct of safety assessment, reporting and analyses of safety occurrences at heliport and continuous monitoring to enforce compliance with applicable specifications so that identified risks are mitigated can be found in the PANS-Aerodromes (Doc 9981).



The heliport operator shall also identify the accountabilities of all members of management, irrespective of other functions, as well as of employees, with respect to the safety performance of the SMS. Safety responsibilities, accountabilities and authorities shall be documented and communicated throughout the organisation, and shall include a definition of the levels of management with authority to make decisions regarding safety risk tolerability.

The Heliport Emergency Plan, shall be part of the structure of the heliport *Safety Management System Manual* (SMSM) and it establishes, in writing, the actions to be adopted after an accident and designates the accountable individuals. The aim of a Heliport Emergency Plan is to ensure an efficient and organised transition from normal to emergency operations including delegating emergency authorities and responsibilities. The authorisation for the measures to be taken by key personnel is also part of the plan; as well as the activity coordination with the emergency response. The general objective is continuing the operations under safe conditions or returning to normal operations as soon as possible.

AC 9.15 Safety Audits and Inspections

(See AGA 2 para 9.15)

Guidance on carrying out daily inspections of the movement area is given in the Airport Services Manual (Doc 9137), Part 8 and in the Manual of Surface Movement Guidance and Control Systems (SMGCS) (Doc 9476).

Examples of agencies are:

- on the heliport: air traffic control units, rescue and firefighting services, heliport administration, medical and ambulance services, aircraft operators, security services, and police;
- off the heliport: fire departments, police, health authorities (including medical, ambulance, hospital and public health services), military, and harbour patrol or coast guard.

Public health services include planning to minimize adverse effects to the community from health-related events and deal with population health issues rather than provision of health services to individuals.

AC 9.16 Vehicles

(See AGA 2 para 9.16)

Ground Vehicle Operations on Airports (Doc AC 150/521B0-20) offers acceptable standards.

a) Objective.

This AC offers guidance for standard identification of vehicles used on the airside of the heliport.

b) Definitions.

- 1) Vehicles: Any means of transport used for transportation or assistance for people, cargo, equipping, maintenance, construction, services or security related tasks.
- 2) Heliport (airfield) service vehicles: Those vehicles routinely used for service, maintenance or construction of the heliport such as runway sweepers, tractors or any other vehicle of the same category.
- 3) Aircraft support vehicles: Those vehicles commonly used to support aircraft operations such as: towing tractors, baggage tow tractors, air conditioning units, road tankers and any other transport of the same category.
- 4) Other vehicles: Those vehicles not commonly used in the heliport operations such as ambulances, rescue and firefighting vehicles and security vehicles.

c) Colours

- 1) Ambulances: They shall be coloured according to the dispositions of the corresponding authority (Red Cross).
- 2) Rescue and firefighting vehicles: Yellowish green is the standard colour for heliports. This colour provides optimal visibility in different luminance levels throughout the 24 hours of the day.



- 3) Heliport Service vehicles: Chrome yellow is the standard colour for vehicles. If they have a bar type bumper of 20 cm or more, they shall be coloured with black and yellow alternating contrasting bands and they shall have 10 cm in width with 45° inclination.
 - 4) Security and aircraft support vehicles: Any colour combination except yellowish green or chrome yellow. The recommendation related to bumpers in the previous paragraph is also applicable.
 - 5) Other vehicles: Any colour or combination
- d) Markings
- 1) Ambulances: They shall be marked according to the dispositions of the corresponding authority (Red Cross).
 - 2) Rescue and firefighting, service, aircraft support and security vehicles: They shall have an identification number contrasting with the colour of the vehicle on the sides and top (the cabin is considered the top of the vehicle). The side numbers shall be appropriately located and at a minimum height of 40 cm. Numbers on the top shall be at least 60 cm high facing forward the vehicle. To improve night recognition, a horizontal reflective band of 20 cm in width shall be painted or added across the vehicle. Additionally, it shall have the name of the heliport, the company or logo.
 - 3) Other vehicles: Vehicles which usually do not access the manoeuvring area or which are not in contact with ATS, shall be provided with an easily visible flag attached to the vehicle. The flag shall be at least 90 cm², with a chequered pattern of 30 cm in orange and white. Moreover, they shall be equipped with two-way radios to communicate with ATS. At heliports without ATS, the flag shall be provided on the vehicle.

d) Lighting

The standard light to identify vehicles operating in the airfield, either at night or when visibility is low, shall be the rotating beacon or flashing light, on top of the highest part of the vehicle and visible from any direction, even from the air. Vehicles, which not operate normally in the airfield, shall be identified with a light during low visibility periods or be escorted by a properly identified vehicle.

Characteristics:

- 1) Headlamp or flashing lights shall have low luminous intensity, with a boundary of 400 cd to avoid interference of night vision. The minimum interference intensity at horizontal plane shall be 40 cd.
- 2) Azimuthal horizontal coverage of 360°
- 3) For flashing lights, the flash range shall be between 75 ± 15 per minute.

Colour:

- 1) Ambulances: as provided by the corresponding authority (Red Cross).
- 2) Rescue and firefighting vehicles: Flashing-red lights, red and white flashing combination or rotating beacon if the station is close to the apron.
- 3) Service vehicles: Flashing-yellow lights.
- 4) Aircraft support vehicles: Yellow or red rotating beacons.
- 5) Security vehicles: Flashing-blue lights or a red and blue flashing combination.
- 6) Other vehicles: Flashing-yellow lights.
- 7) Other requirements:
 - l) Permission or security seal issued by the heliport operator



- II) Technical review approval by the heliport operator
- III) Copy of the vehicle insurance policy

AC 9.17 Control of obstacles

(See AGA 2 para 9.17)

The *Airport Services Manual* (Doc 9137), Part 6: obstacle limitation surfaces, and ICAO's Doc PANS-OPS establish the implementation criteria on obstacle limitation surfaces, particularly for operating heliports.

AC 9.19 Public protection

(See AGA 2 para 9.19)

- a) The perimeter of the airside as well as the restricted security area shall be outlined and protected with physical barriers. However, as the perimeter of a restricted security area is adjacent to open areas, including the airside, these perimeter sections shall be patrolled or be kept under surveillance to ensure that any non-authorised access is detected and intruders may be promptly arrested before they have access to aircraft or other essential facilities.
- b) All airside shall be protected, whether they are part of the restricted security areas or not, by separating them from adjacent landside through fences or other effective security means.
- c) Fencing shall be at least 2.44 meters high. Supporting pipes shall have an angle of 45° to prevent possible access. In addition, fencing shall have at least 4 barbed wires or razor wire type.
- d) In some places, where a fence or barrier may become an obstacle for safety, it may not be possible to build fences or barriers that fully meet safety conditions; for example, near navigation systems and approach or take-off areas. In such cases, special non-metallic fencing materials or construction methods such as frangible fences including plants or thorny bushes combined with intrusion detection equipment and surveillance may be required.
- e) Each building located in the perimeter of the security restricted area, or which leads to that area, shall be protected enough to ensure that no one may access it through, or over, that building without authorisation. This requires that all open areas, such as windows or vents which may allow access to security restricted areas, shall be protected with locks and provided with barriers, grilles and wire mesh. The roof of the building may be a possible route for unauthorised access and shall be protected in a similar manner, especially when building cables are attached to the perimeter fence of the security restricted area.
- f) Places where there are land characteristics such as water areas, barriers, etc. in the airfield or the perimeter of the security restricted area shall be as protected as the fencing. It is necessary to take care of transitional areas, from fences to natural barriers, to ensure the integrity of the perimeter. In case of navigable watercourses, they shall be patrolled by boats, in addition to regular patrols along the shore.

AC 9.20 Protection against wildlife strike hazards

(See AGA 2 para 9.20)

The presence of wildlife (birds and animals) on and in the heliport vicinity poses a serious threat to helicopter operational safety.

- a) Appropriate guidance on wildlife strike hazard is given in ICAO *Airport Services Manual*, Part 3. DOC 4332-1815 contains the *Bird Strike Information System* (IBIS) to notify ICAO.
- b) The IBIS is designed to collect and disseminate information on wildlife strikes to aircrafts. Information on the system is included in the Manual on the ICAO *Bird Strike Information System* (IBIS) (Doc 9332).

AC 9.21.4(c) Notifying and reporting about heliport conditions

(See AGA 2 para 9.21.4(c))

Nature, format and conditions of the information to be provided are specified in CAR AIS and PANS-ATM (Doc 4444).

Other contaminants may include mud, dust, sand, volcanic ash, oil and rubber. Procedures for monitoring and reporting the conditions of the movement area are included in the PANS-Aerodromes (Doc 9981).



The determination that a runway or portion thereof may be slippery when wet is not based solely on the friction measurement obtained using a continuous friction measuring device. Supplementary tools to undertake this assessment are described in the Airport Services Manual (Doc 9137), Part 2.

The surface friction characteristics of a runway or a portion thereof can be degraded due to rubber deposits, surface polishing, poor drainage or other factors. The determination that a runway or portion thereof is slippery wet stems from various methods used solely or in combination. These methods may be functional friction measurements, using a continuous friction measuring device, that fall below a minimum standard as defined by the State, observations by heliport maintenance personnel, repeated reports by pilots and aircraft operators based on flight crew experience, or through analysis of aeroplane stopping performance that indicates a substandard surface. Supplementary tools to undertake this assessment are described in the PANS-Aerodromes (Doc 9981).

Guidance on training criteria is included in the Airport Services Manual (Doc 9137), Part 8, Chapter 7.

The Aeroplane Performance Manual (Doc 10064) provides guidance on aircraft performance calculation requirements regarding the description of runway surface conditions.

Origin and evolution of data, assessment process and the procedures are prescribed in the PANS-Aerodromes (Doc 9981). These procedures are intended to fulfil the requirements to achieve the desired level of safety for aeroplane operations prescribed by CAR OPS 1 and to provide the information fulfilling the syntax requirements for dissemination specified in Annex 15 and the PANS-ATM (Doc 4444).

AC 9.21.9 Notifying and reporting about heliport conditions

(See AGA 2 para 9.21.9)

- a) The runway surface conditions are those conditions for which, by means of the methods described in the PANS-Aerodromes (Doc 9981), the flight crew can derive appropriate aeroplane performance.
- b) The conditions, either singly or in combination with other observations, are criteria for which the effect on aeroplane performance is sufficiently deterministic to allow assignment of a specific runway condition code.
- c) The terms CHEMICALLY TREATED and LOOSE SAND do not appear in the aeroplane performance section but are used in the situational awareness section of the runway condition report.
- d) Procedures on depth and coverage reporting are found in the PANS-Aerodromes (Doc 9981).
- e) Surface friction characteristics of a runway or a portion thereof can be degraded due to rubber deposits, surface polishing, poor drainage or other factors. The determination that a runway or portion thereof is slippery wet stems from various methods used solely or in combination. These methods may be functional friction measurements, using a continuous friction measuring device, that fall below a minimum standard as defined by the State, observations by heliport maintenance personnel, repeated reports by pilots and aircraft operators based on flight crew experience, or through analysis of aeroplane stopping performance that indicates a substandard surface. Supplementary tools to undertake this assessment are described in the PANS-Aerodromes (Doc 9981).
- f) Guidance on determining and expressing the minimum friction level is provided in the ICAO Circular 329 – Assessment, Measurement and Reporting of Runway Surface Conditions.
- g) Procedures on conducting a runway surface friction characteristics evaluation programme are provided in the PANS-Aerodromes (Doc 9981).
- h) Information to be promulgated in a NOTAM includes specifying which portion of the runway is below the minimum friction level and its location on the runway.

AC 9.23 Apron management service

(See AGA 2 para 9.23)

ICAO *Airport Services Manual*, Part 8, and the *Manual of Surface Movement Guidance and Control Systems* (SMGCS), offer guidance on apron management service.

Guidance on related special procedures is given in the *Manual of Surface Movement Guidance and Control Systems* (SMGCS) (Doc 9476).



See the *Airport Services Manual* (Doc 9137), Part 5: It provides guidance and standardised procedures on the development of the disabled aircraft movement and removal plan.



This Page Intentionally Left Blank



CHAPTER 10

LICENSING PROCESS

AC 10.1 Licensing Process

(See AGA 2 para 10.1)

To obtain a heliport licence, the applicant must undergo a licensing process, which is formally recorded in a heliport certification file by the Authority. This process consists of the following stages:

Stage 1 - Pre-application

This is the process where the applicant expresses an interest in obtaining a heliport licence and obtains the information required relating to the granting of a heliport licence. During this stage, the first meeting between the applicant and the Authority takes place, where there is an information exchange on service and guidance in regards to the regulations, standards, procedures, responsibilities and privileges of the service that the applicant intends to provide, and the technical documentation to be submitted.

Stage 2 - Formal Application

The applicant shall submit the a formal application to the Authority attaching the schedule of events for the licensing process, the Heliport Operations Manual (HOM) required by these regulations, the Heliport Security Programme required by CAR SEC and the SMS of the heliport required by CAR SMS.

Stage 3 – Evaluation

The Authority conducts a thorough review of the documentation submitted and informs the applicant of any discrepancies found; otherwise, provisional approval/acceptance is issued.

Stage 4 - Technical Evaluation

The applicant is subjected to a technical demonstration and evaluation to determine compliance with the facilities with respect to signals, lighting, markings, pavements, obstacles, rescue and firefighting services, equipment, personnel, procedures, SMS, apron management, wildlife strike hazard and training.

Stage 5 – Certification

Once stages 1 to 4 have been successfully completed, the Authority shall grant the heliport certificate with any conditions established for promulgation in the Bahamas AIP.

AC 10.1.7 Key Personnel

(See AGA 2 para 10.1.7)

The heliport operator must submit to the Authority, for its approval, key operations and maintenance personnel of the heliport-

- a) Operations:
 - 3) Higher education in engineering or heliport administration, or an aviation technician license or any other career related to heliport operations.
 - 4) A minimum of five years of experience in heliport management.
- b) Maintenance:
 - 4) Higher education in civil, mechanical, or electric engineering, construction or architecture or a qualified technician with proven experience subjected to Authority approval.
 - 5) Heliport specialised courses.
 - 6) Three years of proven experience in positions related to supervision and inspection of the movement area or two years subject to a training plan proposed by the heliport operator and approved by the Authority.



- c) Safety Management
- 3) Qualified technician with proven knowledge and experience in SMS.
 - 4) A minimum of three years of proven experience in quality systems or heliport SMS.

Any change in the authorised key personnel payroll, must be submitted to the Authority for approval.

AC 10.1.8 Safety management systems

(See AGA 2 Para 10.1.8)

The intent of a safety management system is to have in place an organised and orderly approach in the management of heliport safety by the heliport operator. CAR SMS - Safety Management Systems contains the safety management provisions applicable to certified/licensed heliports.

The Director General, in exercise of the powers conferred by Section 17(1) of the Civil Aviation Authority Bahamas Act, 2021 (*No. 2 of 2021*) hereby issues the forgoing regulation.

Issued the 25th day of March 2021

**DIRECTOR GENERAL
CIVIL AVIATION AUTHORITY BAHAMAS**